

Total Chlorine Analyzer with Model 56



ESSENTIAL INSTRUCTIONS

READ THIS PAGE BEFORE PROCEEDING!

Rosemount Analytical designs, manufactures, and tests its products to meet many national and international standards. Because these instruments are sophisticated technical products, you must properly install, use, and maintain them to ensure they continue to operate within their normal specifications. The following instructions must be adhered to and integrated into your safety program when installing, using, and maintaining Rosemount Analytical products. Failure to follow the proper instructions may cause any one of the following situations to occur: Loss of life; personal injury; property damage; damage to this instrument; and warranty invalidation.

- Read all instructions prior to installing, operating, and servicing the product. If this Instruction Manual is not the correct manual, telephone 1-800-654-7768 and the requested manual will be provided. Save this Instruction Manual for future reference.
- If you do not understand any of the instructions, contact your Rosemount representative for clarification.
- Follow all warnings, cautions, and instructions marked on and supplied with the product.
- Inform and educate your personnel in the proper installation, operation, and maintenance of the product.
- Install your equipment as specified in the Installation Instructions of the appropriate Instruction Manual and per applicable local and national codes. Connect all products to the proper electrical and pressure sources.
- To ensure proper performance, use qualified personnel to install, operate, update, program, and maintain the product.
- When replacement parts are required, ensure that qualified people use replacement parts specified by Rosemount. Unauthorized parts and procedures can affect the product's performance and place the safe operation of your process at risk. Look alike substitutions may result in fire, electrical hazards, or improper operation.
- Ensure that all equipment doors are closed and protective covers are in place, except when maintenance is being performed by qualified persons, to prevent electrical shock and personal injury.

WARNING

ELECTRICAL SHOCK HAZARD

Making cable connections to and servicing this instrument require access to shock hazard level voltages which can cause death or serious injury.

Be sure to disconnect all hazardous voltage before opening the enclosure.

Relay contacts made to separate power sources must be disconnected before servicing.

Electrical installation must be in accordance with the National Electrical Code (ANSI/NFPA-70) and/or any other applicable national or local codes.

Unused cable conduit entries must be securely sealed by non-flammable closures to provide enclosure integrity in compliance with personal safety and environmental protection requirements.

The unused conduit openings need to be sealed with NEMA 4X or IP65 conduit plugs to maintain the ingress protection rating (IP65).

For safety and proper performance this instrument must be connected to a properly grounded three-wire power source.

Proper relay use and configuration is the responsibility of the user.

No external connection to the instrument of more than 69VDC or 43V peak allowed with the exception of power and relay terminals. Any violation will impair the safety protection provided

Do not operate this instrument without front cover secured. Refer installation, operation and servicing to qualified personnel.

WARNING

This product is not intended for use in the light industrial, residential or commercial environment, per the instrument's certification to EN50081-2.


Emerson Process Management

2400 Barranca Parkway
Irvine, CA 92606 USA
Tel: (949) 757-8500
Fax: (949) 474-7250

<http://www.raihome.com>

! WARNING


HAZARDOUS VOLTAGE



Can cause severe injury or death.
Disconnect power before servicing.

! VYSTRAHA


NEBEZPECNE NAPETI



Muze způsobit vážne zranení nebo smrt.
Odpojte napájení před údržbou.

! AVISO

VOLTAJE PELIGROSO



Puede causar severas lesiones o muerte.
Desconecte la alimentación antes del mantenimiento.

! ADVARSEL


FARLIG SPÆNDING



Kan forårsage alvorlige kvæstelser eller død.
Afbryd spænding før servicering.

! ATTENTION


HAUTE TENSION



Peut provoquer des blessures graves ou la mort.
Déconnecter l'alimentation avant manipulation.

! OSTRZEZENIE


NIEBEZPIECZNE NAPIECIE



Może spowodować uszkodzenie ciała lub śmierć. Odlacz zasilanie przed przystąpieniem do prac.

! WARNUNG

GEFAEHRLICHE SPANNUNG



Am Gerät liegt eine gefährliche Spannung an. Schalten Sie immer vor dem Öffnen des Gerätes alle Zuleitungen spannungsfrei.

! Waarschuwing

GEVAARLIJKE SPANNING



Kan ernstig of dodelijk letsel veroorzaken.
Schakel de voeding uit voordat u onderhoudswerkzaamheden uitvoert.

! Attenzione

ALTA TENSIONE



Può causare grave lesione o morte.
Disattivare le tensioni prima di effettuare la manutenzione.

! ADVARSEL

FARLIG SPENNING



Kan føre til alvorlige skader eller dødsulykker.
Spenningsstiftørsel må frakobles før service utføres.

! VARNING


LIVSFARLIG SPÄNNING



Kan medföra allvarlig skada eller dödsfall.
Bryt spänning innan service utföres.

! AVISO

TENSÃO PERIGOSA



Pode causar lesões graves ou a morte.
Desligar a energia antes de proceder a trabalhos de manutenção.



DANGER

HAZARDOUS AREA INSTALLATION

Installations near flammable liquids or in hazardous area locations must be carefully evaluated by qualified on site safety personnel. This device is not Intrinsically Safe or Explosion Proof.

To secure and maintain an intrinsically safe installation, the certified safety barrier, transmitter, and sensor combination must be used. The installation system must comply with the governing approval agency (FM, CSA or BASEEFA/CENELEC) hazardous area classification requirements. Consult your analyzer/transmitter instruction manual for details.

Proper installation, operation and servicing of this device in a Hazardous Area Installation is entirely the responsibility of the user.



CAUTION

SENSOR/PROCESS APPLICATION COMPATIBILITY

Wetted materials may not be compatible with process composition and operating conditions. Application compatibility is entirely the responsibility of the user.

About This Document

This manual contains instructions for installation and operation of the Model TCL56 Total Chlorine Analyzer.

The following list provides notes concerning all revisions of this document.

<u>Rev. Level</u>	<u>Date</u>	<u>Notes</u>
A	5/11	This is the initial release of the product manual. The manual has been reformatted to reflect the Emerson documentation style and updated to reflect any changes in the product offering.

MODEL TCL-56 TOTAL CHLORINE ANALYZER

TABLE OF CONTENTS

Section	Title	Page
1.0	DESCRIPTION AND SPECIFICATIONS	1
1.1	Features	1
1.2	Specifications — Sample Conditioning System	3
1.3	Specifications — Model 56 Analyzer	3
1.4	Specifications — Model 499ACL-02 Sensor.....	4
1.5	Performance Specifications — Complete System	4
1.6	Ordering Information and Accessories	5
2.0	PRINCIPLES OF OPERATION	7
3.0	INSTALLATION	8
3.1	Unpacking and Inspection	8
3.2	Installation.....	8
4.0	WIRING	13
4.1	Prepare Analyzer Conduit Openings	13
4.2	Provide Power to the Sample Conditioning System	13
4.3	Make Power, Alarm, Output, and Sensor Connections in the Analyzer.....	14
4.4	Sensor Wiring	15
4.5	Apply Power to the Analyzer and Complete Quick Start.....	16
5.0	START-UP	17
5.1	Prepare the Reagent	17
5.2	Zero the Sensor	17
5.3	Start Sample Flow.....	17
5.4	Begin Operation and Calibrate the Sensor	17
6.0	DISPLAY AND OPERATION	18
6.1	Main Display	18
6.2	Keypad.....	18
6.3	Operation	19
6.4	Hold	21
6.5	Main Display	22
6.6	Security.....	23
7.0	PROGRAMMING THE ANALYZER	24
7.1	Entering the Program Menus.....	24
7.2	Outputs	24
7.3	Relays.....	25
7.4	Measurement.....	27
7.5	Temperature.....	27
7.6	Security.....	28
7.7	Restoring Default Settings.....	28

TABLE OF CONTENTS CONT'D.

8.0	CALIBRATION	29
8.1	Introduction.....	29
8.2	Entering the Calibration Menus	29
8.3	Calibrating Temperature	29
8.4	Calibrating the Free Chlorine Sensor	30
8.5	Calibrating the Analog Outputs.....	30
8.6	Reset	31
9.0	DATA AND EVENT LOGGING AND RETRIEVAL	33
9.1	Overview.....	33
9.2	Configuration	33
9.3	Downloading Data and Events	34
9.4	Viewing Events	34
9.5	Date and Time	34
10.0	GRAPHICAL DISPLAY	35
10.1	Overview.....	35
10.2	Configuration	35
11.0	DIGITAL COMMUNICATIONS	36
12.0	MAINTENANCE	37
12.1	Analyzer.....	37
12.2	Total Chlorine Sensor	38
12.3	Sample Conditioning System.....	40
13.0	TROUBLESHOOTING	47
13.1	Overview.....	47
13.2	Reading and Troubleshooting Fault and Warning Messages	47
13.3	Sensor Diagnostics.....	48
13.4	Troubleshooting Calibration Problems.....	48
13.5	Other Troubleshooting	48
13.6	Other Troubleshooting - General	50
13.7	Simulating Inputs - Chlorine.....	51
13.8	Simulating Inputs - Temperature	52
14.0	RETURN OF MATERIAL	53
14.1	General	53
14.2	Warranty Repair.....	53
14.3	Non-Warranty Repair	53

LIST OF TABLES

Number	Title	Page
12-1	Spare Parts	39
12-2	Replacement Parts and Reagent for Sample Conditioning System	46

LIST OF FIGURES

Number	Title	Page
2-1	Schematic of Sample Conditioning System and Analyzer	7
3-1	Panel Mounting Dimensions	9
3-2	Pipe and Wall Mounting Dimensions	10
3-3	Installing the Sample Conditioning Enclosure.....	11
3-4	TCL Case Dimensions	12
3-5	Reagent Tubing Assembly	12
4-1	Power Wiring	13
4-2	Analog output connections.....	14
4-3	Alarm relay connections.....	15
4-4	Wiring Sensor with Optimum EMI/RFI or Variopool Cable to Model 56 Analyzer.....	16
4-5	Wiring Sensor with Standard Cable to Model 56 Analyzer.....	16
6-1	Main Display	18
6-2	Analyzer keypad	18
7-1	Menu Tree for the Outputs Submenu	24
7-2	Menu Tree for the Relays Submenu	25
7-3	Menu Tree for the Measurements Submenu	27
7-4	Menu Tree for the Temperature Submenu	27
7-5	Menu Tree for the pH Diagnostic Setup Submenu	28
12-1	Sensor Board Connections	37
12-2	Sensor Parts	39
12-3	Replacing Reagent Tubing.....	40
12-4	Replacing Sample Tubing	41
12-5	Peristaltic Pump Tubing	42
12-6	Pump Cover	42
12-7	Removing the Cover	42
12-8	Inserting New Tube.....	42
12-9	Replace the Cover	43
12-10	Bottom of the Cover	43
12-11	Tracks	43
12-12	Disconnection	44
12-13	Removal of Screws.....	44
12-14	Connect the Air Inlet and Outlet Tubing to the Air Pump.....	44
12-15	Schematic	44
12-16	Remove the Air Inlet Fitting.....	45
12-17	Slide Pump Assembly Out of the Air Pump Body.....	45
13-1	Disconnecting Sample and Reagent Tubing Prior to Checking Flow.....	49
13-2	Simulating Chlorine.....	51
13-3	Three Wire RTD Configuration	52
13-4	Simulating RTD Inputs	52

SECTION 1.

DESCRIPTION AND SPECIFICATIONS

Model TCL Sample Conditioning System

- **NO METAL WETTED PARTS.** Ideal for seawater.
- **LOW SAMPLE FLOW** (about 15 mL/minute) means little waste.
- **REAGENT-BASED SYSTEM** measures true total chlorine.
- **FIVE GALLONS OF REAGENT** lasts two months.

Model 56 Chlorine Analyzer

- **LARGE, PROGRAMMABLE, FULL COLOR DISPLAY** with easy to use interface.
- **FOUR INDEPENDENT OUTPUTS** with HART digital communication standard.
- **FOUR FULLY PROGRAMMABLE RELAYS.**
- **DATA LOGGER** and graphical display standard.

Model 499A CL-02 Sensor

- **MEMBRANE-COVERED AMPEROMETRIC SENSOR.**
- **NO TOOLS REQUIRED** to change membrane.
- **MAINTENANCE TAKES ONLY A FEW MINUTES** a month.
- **VARIOPOL CONNECTOR OPTION** allows the sensor to be replaced without removing and rewiring cable.

1.1 FEATURES

MODEL TCL SAMPLE CONDITIONING SYSTEM

The sample conditioning system permits a single sensor to measure total chlorine in water. The sample conditioning system continuously injects a solution of acetic acid (vinegar) and potassium iodide into the sample. The acid lowers the pH to between 3.5 and 4.5 and allows total chlorine in the sample to quantitatively react with the potassium iodide to produce iodine. The sensor measures the iodine concentration, and the analyzer displays the total oxidant concentration in ppm as Cl_2 .

MODEL 56 CHLORINE ANALYZER

The Model 56 chlorine analyzer is intended for the continuous determination of chlorine in water. When used with the TCL and 499ACL-02 sensor it measures total chlorine.

The analyzer is housed in a corrosion resistant NEMA 4X enclosure. It is suitable for panel, pipe, or wall

mounting. The large, high resolution, full color display shows total chlorine concentration and temperature in 0.5 inch (13 mm) high characters. Six other user-selectable variables can be shown in smaller characters. Operation of the analyzer is through a membrane keypad.

Calibration and programming screens are simple and intuitive. Plain language prompts in nine languages guide the user. Information about program settings and calibration, as well as troubleshooting guidance is available on-screen at the press of a button.

The analyzer has four fully programmable analog outputs, with HART digital communication superimposed on output 1. Profibus DP digital communications is available as an option. PID control is standard.

Four fully programmable relays are available. Relays can be configured as simple high/low setpoint alarms or can be used to perform a number of timer functions

as well as time proportional control (TPC). For more information about relay actions refer to Product Data Sheet 71-56.

A data and event logger are standard. The data logger stores up to 30 days of data, and the event logger stores up to 300 events. Events can be viewed on screen, and data can be shown in a full color dual graphics display. Data and events can also be downloaded through a USB port on the front panel of the analyzer.

MODEL 499A CL-02 SENSOR

The Model 499ACL-02 total chlorine sensor is used in the TCL sample conditioning system. Although the sensor is called a chlorine sensor, it really measures iodine. The iodine comes from the reaction between oxidants in the sample and the acetic acid/potassium iodide reagent added by the sample conditioning system.

The sensor consists of a gold cathode and a silver anode in an electrolyte solution. A silicone membrane, permeable to iodine, is stretched over the cathode. The analyzer applies a voltage to the cathode sufficiently negative to reduce all the iodine reaching it. Because the concentration of iodine in the sensor is always zero, a concentration gradient continuously forces iodine from the sample through the membrane into the sensor.

The reduction of iodine in the sensor generates a current directly proportional to the diffusion rate of iodine through the membrane, which is directly proportional to the concentration of iodine in the sample. Because the iodine concentration depends on the amount of total chlorine in the sample, the sensor current is ultimately proportional to the total chlorine concentration.

The permeability of the membrane to iodine is a function of temperature. A Pt100 RTD in the sensor measures the temperature, and the analyzer uses the temperature to compensate the total chlorine reading for changes in membrane permeability.

Sensor maintenance is fast and easy. Replacing the membrane requires no special tools or fixtures. Simply place the membrane assembly on the cathode and screw the retainer in place. Installing a new membrane and replenishing the electrolyte takes only a few minutes.

1.2 SPECIFICATIONS — SAMPLE CONDITIONING SYSTEM

GENERAL

Enclosure: Fiberglass reinforced polyester, NEMA 3 (IP53) suitable for marine environments

Dimensions: 14.5 x 13.0 x 8.6 in. (369 x 329 x 218 mm)

Mounting: Wall

Ambient Temperature: 32° - 122°F (0 - 50°C)

Ambient Humidity: 0 - 90% (non-condensing)

Power: 115 Vac, 6.9 W, 50/60 Hz;
230 Vac, 7.0 W, 50/60 Hz

Hazardous Location: The TCL sample conditioning system has no hazardous location approvals.

Pumps:

EN 809:1998



Weight/Shipping Weight: 14 lb/16 lb (6.5 kg/7.5 kg)

SAMPLE REQUIREMENTS

Inlet Connection: compression fitting, accepts 1/4 in. OD tubing

Drain Connection: 3/4 in. barbed fitting (must drain to open atmosphere)

Inlet Pressure: <100 psig (791 kPa abs)

Flow: at least 0.25 gph (15 mL/min)

Temperature: 32 - 122°F (0 - 50°C)

Total Alkalinity: <300 mg/L as CaCO₃. For samples containing <50 mg/L alkalinity, consult the factory.

SAMPLE CONDITIONING SYSTEM

Reagent: Potassium iodide in vinegar.

Reagent Usage: 5 gallons lasts approximately 60 days.

Reagent Pump: Fixed speed peristaltic pump, about 0.2 mL/min

Sample Pump: Fixed speed peristaltic pump, about 11 mL/min

1.3 SPECIFICATIONS — MODEL 56 ANALYZER

Case: Polycarbonate

Display: Full color LCD, 3.75 x 2.20 in. (95 x 56 mm); display can be customized by the user.

Languages: English, French, German, Italian, Spanish, Portuguese, Chinese, Russian, and Polish.

Ambient Temperature and Humidity: 14 to 140°F (-10 to 60°C); RH 5 to 95% (non-condensing). Between 23 and 131°F (-5 to 55°C) there is no visible degradation in display response or performance.

Storage temperature: -4 to 140°F (-20 to 60°C)

Power: 85 to 265 VAC, 47.5 to 65.0 Hz, 20 W

RFI/EMI: EN-61326



LVD: EN-6101-01

Outputs: Four 4-20 or 0-20 mA isolated current outputs; assignable to measurement or temperature; fully scalable; maximum load 550 Ω. HART digital signal is superimposed on output 1.

Alarms and Timers: Four relays, fully configurable as a setpoint alarm, interval timer, TPC, bleed and feed timer, delay timer, date and time timer, and fault alarm.

Relays: Form C, SPDT, epoxy sealed.

Relay Contact ratings:



5 A at 28 VDC or 300 VAC (resistive)

1/8 HP at 120/240 VAC

Control features: PID control (analog output) and time proportional control or TPC (relays) are standard.

Data logger: Data automatically stored every 30 seconds for 30 days; older data removed to make room for new data. The following data are automatically stored: date and time, ppm, temperature, and raw sensor current.

Event logger: Stores up to 300 events with data and time stamp: faults, warnings, calibration data, calibration results (pass or fail), power on/off cycles, and hold on/off. Alarm relay activation and deactivation can also be stored. Older events are automatically removed to make room for new events.

Data and event downloading: through USB port on front panel.

Graphical display: Dual graphical display shows measurement data on the y-axis and time on the x-axis. The y-axis is fully assignable and scalable. The x-axis can be set to one hour, one day, seven days, or 30 days.

Digital communications: HART digital communications is standard. Profibus DP is optional.

Weight/Shipping Weight: (rounded up to nearest lb or nearest 0.5 kg): 1.5 kg (3 lb)/2.0 kg (4 lb)

1.4 SPECIFICATIONS — MODEL 499ACL-02 SENSOR

Wetted Parts: Gold, Noryl¹ (PPO), Viton², EPDM, Silicone

Dimensions: 1.0 x 5.6 in. (25.4 x 143 mm)

Cable: 25 ft. (7.6m) standard

Pressure Rating: 0 to 65 psig (101 to 549 kPa)

Temperature Rating: 32 to 122°F (0 to 50°C)

Electrolyte Capacity: Approximately 25 mL

Electrolyte Life: Approximately 4 months

Weight/Shipping Weight: 1 lb/3 lb (0.5 kg/1.5 kg)

¹ Noryl is a registered trademark of General Electric.

² Viton is a registered trademark of DuPont Performance Elastomers.

1.5 PERFORMANCE SPECIFICATIONS — COMPLETE SYSTEM

Linear Range: 0 to 20 ppm (mg/L) as Cl₂ (for higher ranges, consult factory)

Linearity (per ISO 15839): 0-10 ppm: 2%; 0-20 ppm: 3%

Response Time: Following a step change in concentration, the reading reaches 90% of final value within 7 minutes at 25°C.

Drift: At about 1.5 ppm in clean water and constant temperature, drift is typically less 0.05 ppm over two weeks.

Detection Limit (per ISO 15839): 0.02 ppm (mg/L) in clean water at room temperature

1.6 ORDERING INFORMATION AND ACCESSORIES

Model TCL Reagent-Based Chlorine System. The TCL is used for the continuous determination of total chlorine in water. The TCL consists of a sample conditioning system, a reagent carboy, a sensor, and an analyzer. **Reagents must be ordered separately. Regent kits for 0-5 ppm and 0-10 ppm chlorine are available. For higher ranges, consult the factory. See ACCESSORIES - Sample Conditioning System.**

MODEL TCL REAGENT-BASED CHLORINE SYSTEM	
CODE	POWER (required selection)
11	115 V 50/60 Hz
12	230 V 50/60 Hz

CODE	ANALYZER (optional selection)
280	56-03-24-38-HT analyzer, with alarm relays, HART
281	56-03-24-38-DP analyzer, with alarm relays, Profibus DP

CODE	SENSOR (optional selection)
30	499ACL-02-54 sensor with standard cable
31	499ACL-02-54-60 sensor with optimum EMI/RFI cable
32	499ACL-02-54-VP sensor with Variopol 6 fitting (interconnecting cable must be ordered separately)

ACCESSORIES — SAMPLE CONDITIONING SYSTEM

PN	Description	Weight*	Ship Weight**
24134-00	Air pump, 115 Vac, 50/60 Hz	1 lb (0.5 kg)	1 lb (0.5 kg)
24134-01	Air pump, 230 Vac, 50/60 Hz	1 lb (0.5 kg)	1 lb (0.5 kg)
9160578	Air pump repair kit	1 lb (0.5 kg)	1 lb (0.5 kg)
9322052	Check valve for air injection line	1 lb (0.5 kg)	1 lb (0.5 kg)
24153-00	Carboy for reagent, 5 gal/19 L, includes cap	4 lb (1.5 kg)	5 lb (2.0 kg)
9100204	Fuse, 0.25 A, 250 V, 3AG, slow blow for option -11 (115 Vac)	1 lb (0.5 kg)	1 lb (0.5 kg)
9100132	Fuse, 0.125 A, 250 V, 3AG, slow blow for option -12 (230 Vac)	1 lb (0.5 kg)	1 lb (0.5 kg)
9380094	Reagent pump, 115 Vac, 50/60 Hz	1 lb (0.5 kg)	2 lb (1 kg)
9380095	Reagent pump, 230 Vac, 50/60 Hz	1 lb (0.5 kg)	2 lb (1 kg)
9380091	Reagent pump replacement tubing	1 lb (0.5 kg)	2 lb (1 kg)
24151-00	Reagent tubing replacement kit	1 lb (0.5 kg)	2 lb (1 kg)
24135-00	Reagent uptake tubing, 6 ft (1.8 m), includes weight	1 lb (0.5 kg)	2 lb (1 kg)
9380090	Sample pump, 115 Vac, 50/60 Hz	1 lb (0.5 kg)	2 lb (1 kg)
9380093	Sample pump, 230 Vac, 50/60 Hz	1 lb (0.5 kg)	2 lb (1 kg)
9380092	Sample pump replacement tubing	1 lb (0.5 kg)	2 lb (1 kg)
24152-00	Sample tubing replacement kit	1 lb (0.5 kg)	2 lb (1 kg)

PN	Description	Weight*	Ship Weight**
24165-00	Acetic acid, 2 x 2.5 gal (9.5 L) bottles/case, with 25 g potassium iodide (0-5 ppm total chlorine)	45 lb (20.5 kg)	48 lb (22.0 kg)
24165-01	Acetic acid, 2 x 2.5 gal (9.5 L) bottles/case, with 50 g potassium iodide (0-10 ppm total chlorine)	45 lb (20.5 kg)	48 lb (22.0 kg)
24164-00	Potassium iodide, 25 g, sufficient for 5 gallons (19 L) of vinegar (0-5 ppm total chlorine)	1 lb (0.5 kg)	1 lb (0.5 kg)
24164-01	Potassium iodide, 50 g, sufficient for 5 gallons (19 L) of vinegar (0-10 ppm total chlorine)	1 lb (0.5 kg)	1 lb (0.5 kg)

*Weights are rounded up to the nearest whole pound or 0.5 kg.

ACCESSORIES — 1055-24 Analyzer

PN	DESCRIPTION	WEIGHT*	SHIP WEIGHT*
9240048-00	Tag, stainless steel, specify marking	1 lb (0.5 kg)	1 lb (0.5 kg)
23820-00	Pipe mounting kit	2 lb (1.0 kg)	3 lb (1.5 kg)

ACCESSORIES — 54eA Analyzer

PN	DESCRIPTION	WEIGHT*	SHIP WEIGHT*
2002577	Wall and two inch pipe mounting kit	2 lb (1.0 kg)	3 lb (1.5 kg)
23545-00	Panel mounting kit	2 lb (1.0 kg)	3 lb (1.5 kg)
23554-00	Cable glands, kit (Qty 5 of PG 13.5)	1 lb (0.5 kg)	1 lb (0.5 kg)
9240048-00	Stainless steel tag (specify marking)	1 lb (0.5 kg)	1 lb (0.5 kg)

ACCESSORIES — Sensor

PN	DESCRIPTION	WEIGHT*	SHIP WEIGHT*
23501-02	Total Chlorine Membrane, includes one membrane assembly and one O-ring	1 lb (0.5 kg)	1 lb (0.5 kg)
23502-02	Total Chlorine Membrane Kit, includes 3 membrane assemblies and three O-rings	1 lb (0.5 kg)	1 lb (0.5 kg)
9210438	Total Chlorine Sensor Fill Solution, 4 oz (120 mL)	1 lb (0.5 kg)	2 lb (1.0 kg)

FOR FIRST TIME VARIOPOL INSTALLATIONS

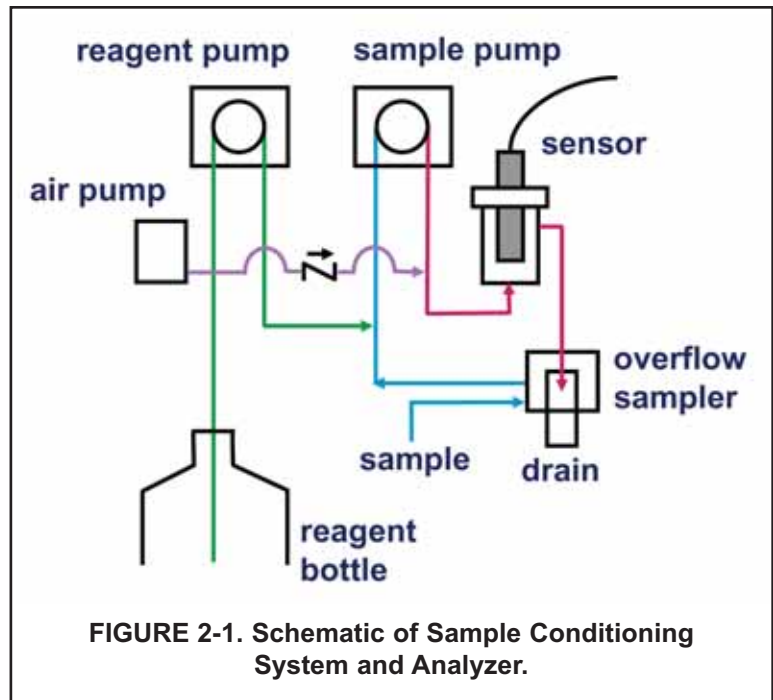
PART #	DESCRIPTION
23747-06	Interconnecting cable, VP 6, 2.5 ft (0.8 m)
23747-04	Interconnecting cable, VP 6, 4 ft (1.2m)
23747-02	Interconnecting cable, VP 6, 10 ft (3.0 m)
23747-07	Interconnecting cable, VP 6, 15 ft (4.6 m)
23747-08	Interconnecting cable, VP 6, 20 ft (6.1 m)
23747-09	Interconnecting cable, VP 6, 25 ft (7.6 m)
23747-10	Interconnecting cable, VP 6, 30 ft (9.1 m)
23747-03	Interconnecting cable, VP 6, 50 ft (15.2 m)
23747-11	Interconnecting cable, VP 6, 100 ft (30.5 m)

*Weights are rounded up to the nearest whole pound or 0.5 kg.

SECTION 2. PRINCIPLES OF OPERATION

Total chlorine by definition is the iodine produced in a sample when it is treated with potassium iodide at a pH between 3.5 and 4.5. Typically, acetic acid (or vinegar) is used to adjust the pH.

The total chlorine analyzer consists of a sample conditioning system, which injects the reagent into the sample, and a sensor and analyzer, which measure the amount of iodine produced. Figure 2-1 shows the sample conditioning system. The sample enters the sample conditioning enclosure and flows to an overflow sampler from which the sample pump takes suction. Excess sample drains to waste. At the same time, the reagent pump draws reagent, a solution of potassium iodide in vinegar, from the reagent carboy and injects it into the suction side of the sample pump. The sample and reagent mix as they pass through the pump, and total chlorine in the sample is converted to the chemically equivalent amount of iodine. The flow rates are 11 mL/min for the sample and 0.2 mL/min for the reagent.



The treated sample next enters the flow cell. Bubbles injected into the flow cell produce turbulence, which improves the stability of the reading. A membrane-covered amperometric sensor in the flow cell measures the concentration of iodine. The analyzer receives the raw signal from the sensor and displays the concentration of total chlorine. Display units are ppm (mg/L) chlorine as Cl_2 . The treated sample leaves the flow cell and drains to waste along with the excess sample.

SECTION 3. INSTALLATION

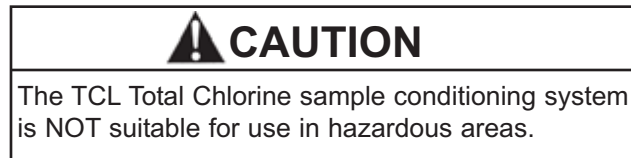
3.1 UNPACKING AND INSPECTION

Inspect the shipping containers. If there is damage, contact the shipper immediately for instructions. Save the boxes. If there is no apparent damage, unpack the containers. Be sure all items shown on the packing list are present. If items are missing, notify Rosemount Analytical immediately.

3.2 INSTALLATION.

3.2.1 General Information

1. Although the analyzer and sample conditioning system are suitable for outdoor use, do not install them in direct sunlight or in areas of extreme temperature.



2. Install the analyzer and sample conditioning system in an area where vibration and electromagnetic and radio frequency interference are minimized or absent.
3. Keep the analyzer and sensor wiring at least one foot from high voltage conductors. Be sure there is easy access to the analyzer and sample conditioning system.
4. The analyzer is suitable for panel, pipe or wall mounting. The sample conditioning enclosure must be mounted on a wall. Provide adequate room beneath the enclosure for the 5-gallon reagent carboy.
5. Be sure that the distance between the analyzer and sample conditioning cabinet does not exceed the length of the sensor cable.

3.2.2 Install the Analyzer

1. Refer to the appropriate figure for installation details.

Type of Mounting	Figure
Panel	3-1
Wall or Pipe	3-2

2. See section 4.1 for more information about the conduit openings.
3. See Section 4.2 for wiring instructions.

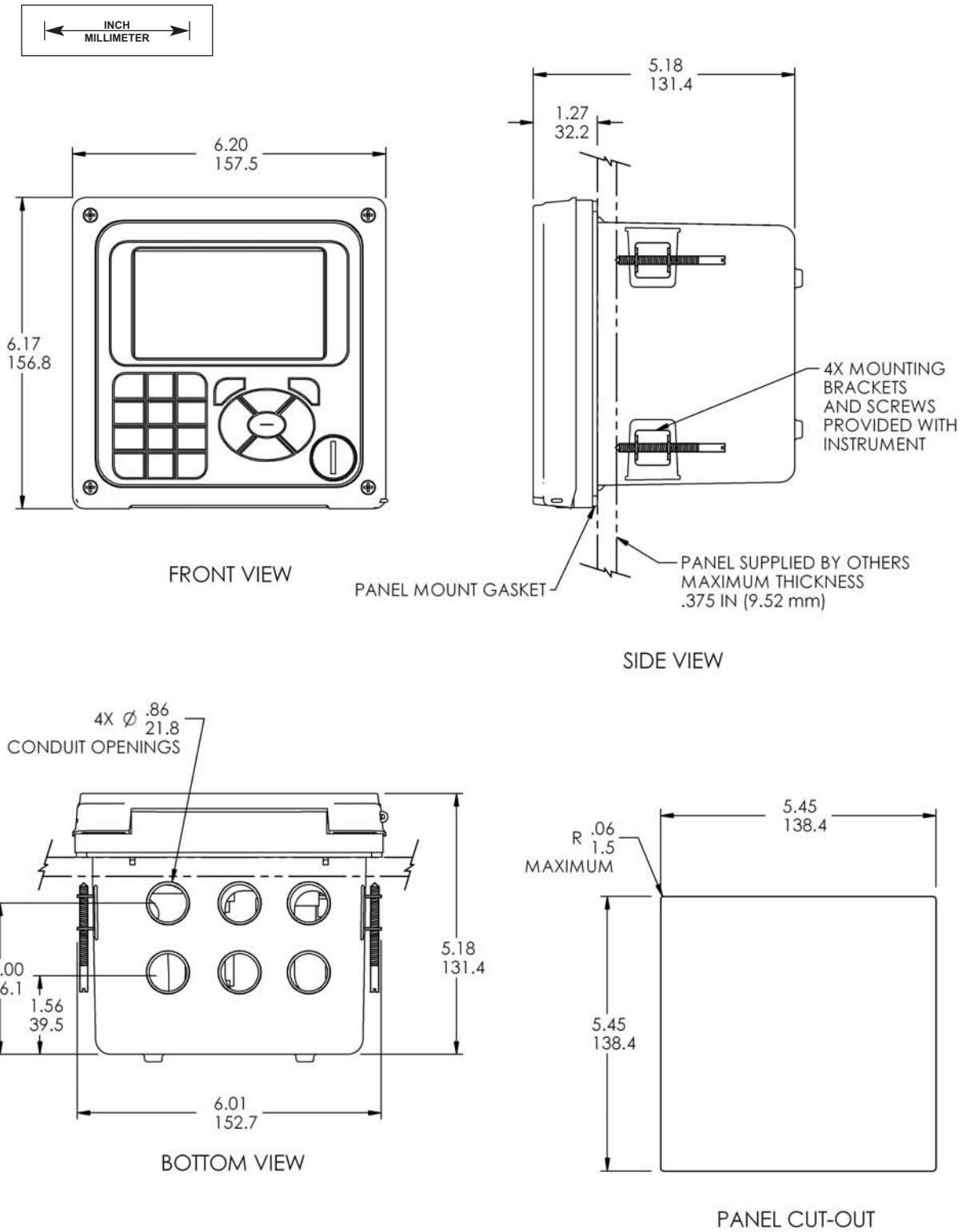
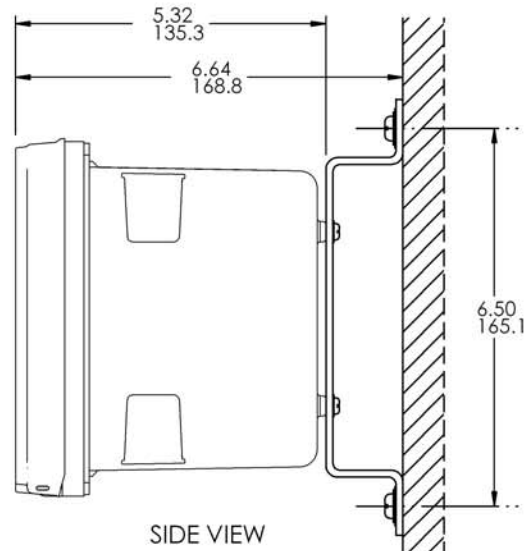
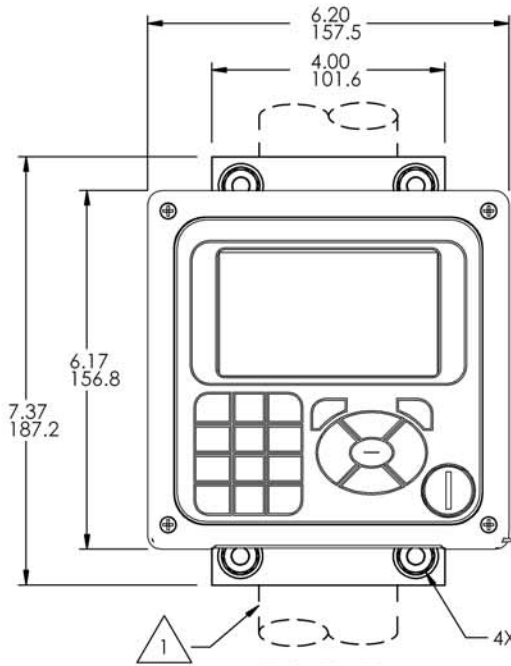


FIGURE 3-1 PANEL MOUNTING DIMENSIONS

TITLE MODEL 56, PANEL MOUNTING DIMENSIONS		
B SIZE	DWG NO 40005602	REV A

INCH
MILLIMETER

WALL / SURFACE MOUNT



WALL / SURFACE MOUNT

2" PIPE SUPPLIED BY CUSTOMER

PIPE MOUNT

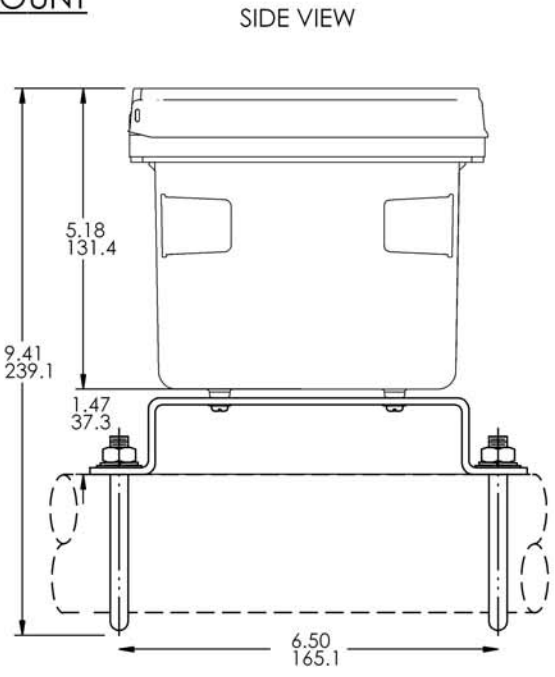
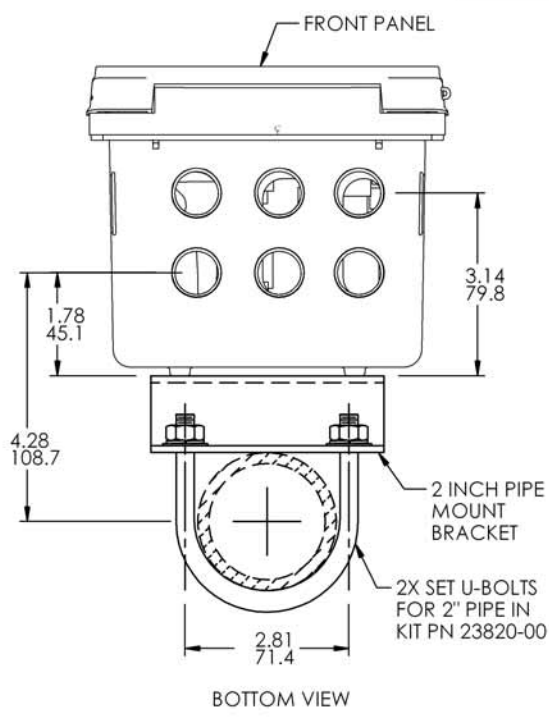


FIGURE 3-2 PIPE AND WALL MOUNTING DIMENSIONS
(Mounting bracket PN:23820-00)

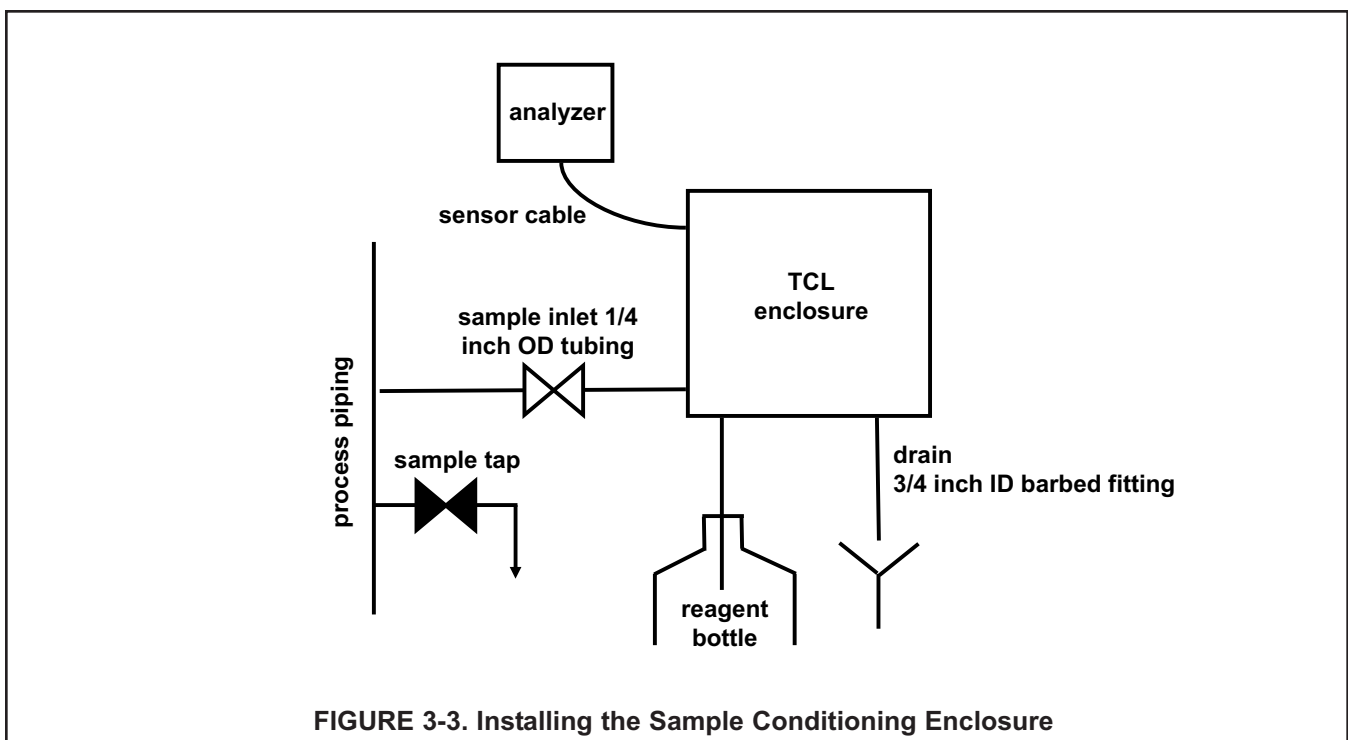
TITLE MODEL 56 W/2" PIPE		
MOUNTING BRACKET /WALL		
MOUNTING DIMENSIONS		
B	DWG NO.	REV
SIZE	40005601	A

3.2.3 Install the Sample Conditioning Enclosure

1. Refer to Figures 3-3, 3-4, and 3-5 for installation details.
2. Connect the sample line to the sample conditioning system. Use ¼-inch OD hard plastic or stainless steel tubing. If dechlorinated water is being measured, provide a way for occasionally substituting a chlorinated water sample for the dechlorinated sample. Chlorinated water is needed to calibrate the sensor and to check its response.
3. If a grab sample tap is not already available, install one in the process piping. Choose a point as close as possible to the sample line supplying the TCL. Be sure that opening the sample valve does not appreciably alter the flow of sample to the instrument.
4. Connect the drain to a length of ¾-inch ID flexible plastic tubing. **The sample must drain to open atmosphere.**
5. Find the reagent tubing and fitting in the plastic bag taped to the inside of the enclosure door. Screw the reagent fitting onto the bulkhead fitting at the bottom left of the enclosure. Pass the reagent tubing through the hole in the carboy cap. Be sure the plastic weight will be inside the carboy when the cap is in place. Attach the reagent tubing to the barbed connector. See Figure 3-5.
6. Place the blue plastic carboy beneath the enclosure. Screw the cap and tubing assembly on to the carboy. To prepare reagent, see Section 5.2.

3.2.4 Install the Sensor

1. From inside the sample conditioning enclosure, thread the sensor cable or VP cable through the gland on the upper left side. Leave about one foot of cable inside the enclosure.
2. Wire the cable to the analyzer. Refer to Section 4.4.
3. Remove the nut and adapter from the flow cell. Slip the nut over the end of the sensor. Thread the adapter onto the sensor. Hand tighten only. If you are using a VP cable, connect the cable to the sensor. The connector and receptacle are keyed to ensure proper mating. Once the key has slid into place, tighten the connection by turning the knurled ring clockwise. Remove the protective cap from the end of the sensor.
4. Insert the sensor in the flow cell. Hand tighten the nut.



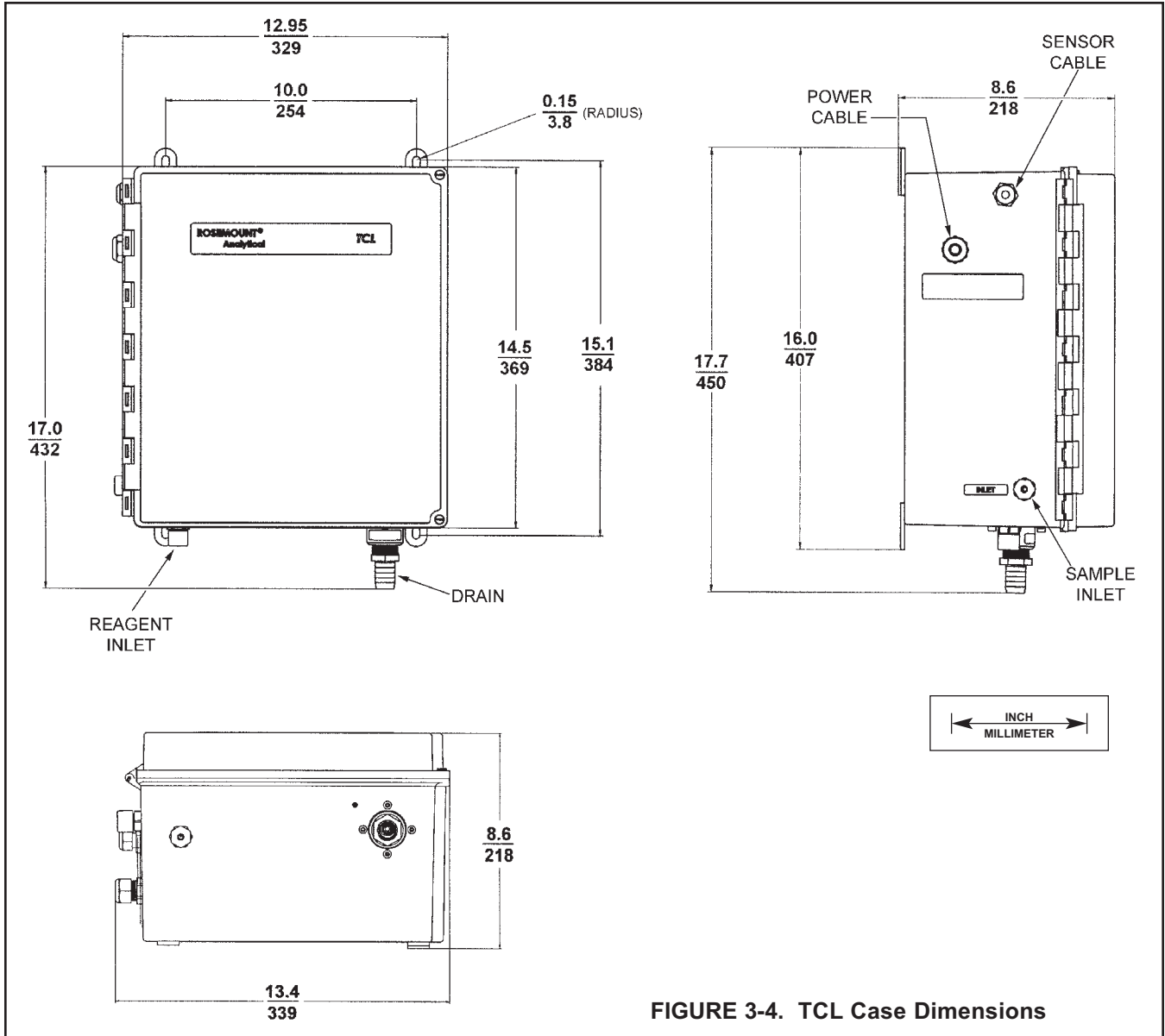


FIGURE 3-4. TCL Case Dimensions

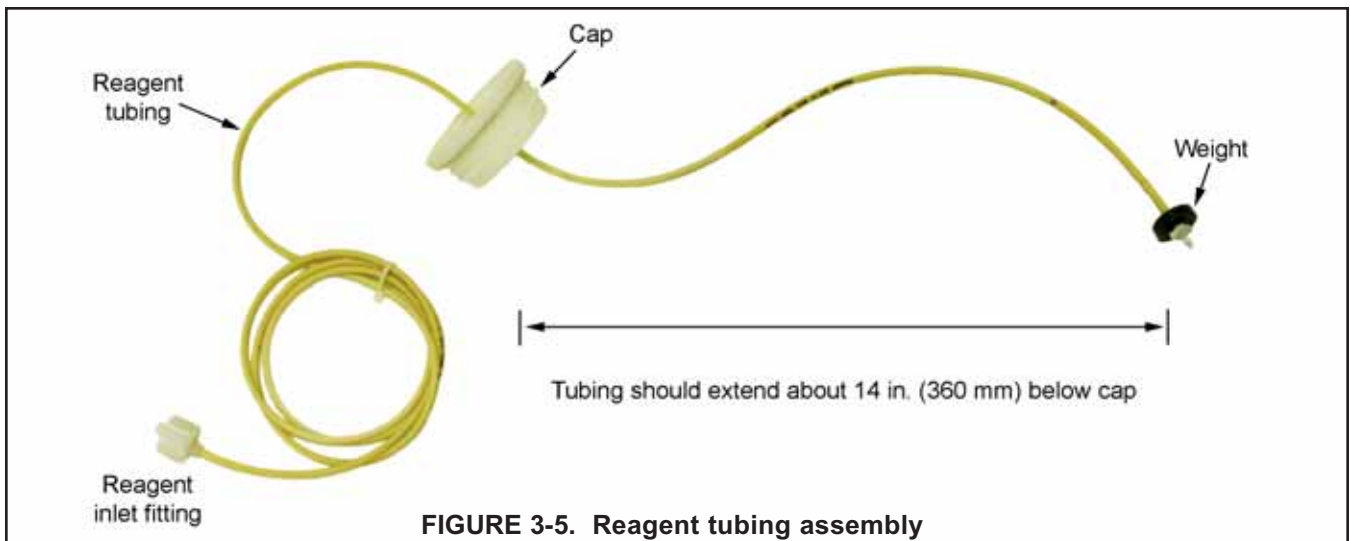


FIGURE 3-5. Reagent tubing assembly

SECTION 4. WIRING

4.1 PREPARE ANALYZER CONDUIT OPENINGS


The analyzer enclosure has six conduit openings. Four conduit openings are fitted with conduit plugs.

Conduit openings accept 1/2-inch conduit fittings or PG 13.5 cable glands. To keep the case watertight, block unused openings with NEMA 4X or IP65 conduit plugs.

NOTE

Use watertight fittings and hubs that comply with the requirements of UL514B. Connect the conduit hub to the conduit before attaching the fitting to the analyzer (UL508-26.16).

4.2 PROVIDE POWER TO THE SAMPLE CONDITIONING SYSTEM



WARNING

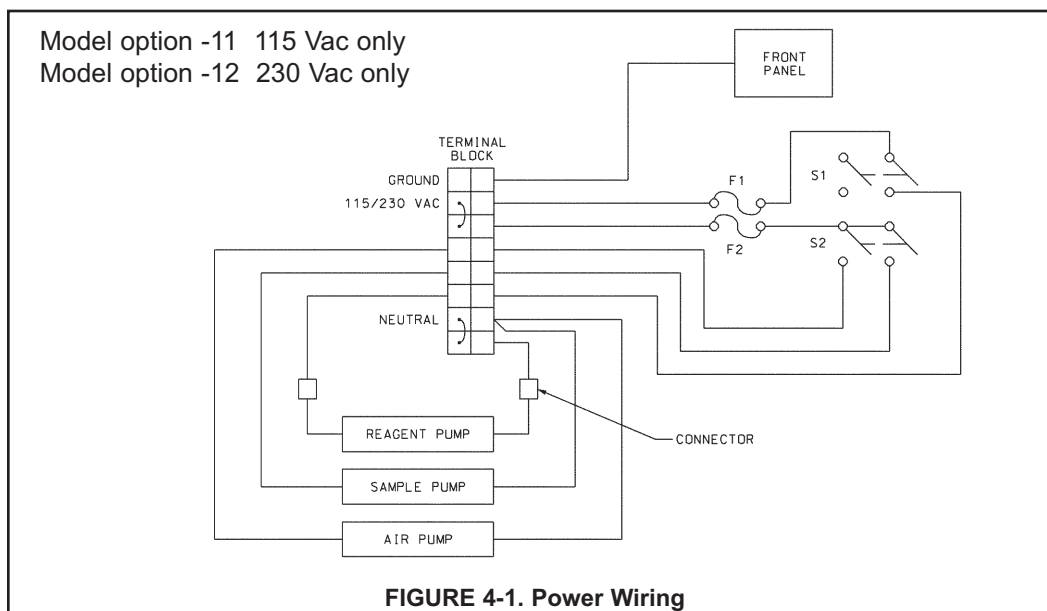
RISK OF ELECTRICAL SHOCK

Electrical installation must be in accordance with the National Electrical Code (ANSI/NFPA-70) and/or any other applicable national or local code.


NOTE

Provide a switch or breaker to disconnect the sample conditioning cabinet from the main power supply. Install the switch or breaker near the unit and identify it as the disconnecting device for the sample conditioning system.

1. Be sure the pump switches on the wiring access panel are in the off position.
2. Remove the four screws securing the wiring access panel. Pull the panel out of the way to reveal the power terminal strip.
3. Insert the power cable through the strain relief connection labeled power (see Figure 3-4). Wire the power cable to the terminal strip as shown in Figure 4-1. Do not apply 230 Vac power to a 115 Vac TCL (Model option -11). Doing so will damage the instrument.
4. **Leave the pump power switches off until ready to start up the unit.** See Section 5.



4.3 MAKE POWER, ALARM, OUTPUT, AND SENSOR CONNECTIONS IN THE ANALYZER



WARNING

RISK OF ELECTRICAL SHOCK

Electrical installation must be in accordance with the National Electrical Code (ANSI/NFPA-70) and/or any other applicable national or local code.

4.3.1 Power

Wire AC mains power to the power supply board, which is mounted on the left hand side of the enclosure beneath the gray plastic cover. To remove the cover, grab it by the upper edges and pull straight out. The power connector is at the bottom of the board. See Figure 4-3. Bring the power cable through the conduit opening just below the connector. Unplug the connector from the board and wire the power cable to it. Lead connections are marked on the connector. (L is live or hot; N is neutral; the ground connection has the standard symbol.)

Replace the cover. The two tabs on the back edge of the cover fit into slots at the rear of the enclosure, and the three small slots in the front of the cover snap into the three tabs next to the relay terminal strip. See Figure 4-3. Once the tabs are lined up, push the cover to snap it in place.

AC power wiring should be 14 gauge or greater. Run the power wiring through the conduit opening nearest the power terminal. Provide a switch or breaker to disconnect the analyzer from the main power supply. Install the switch or breaker near the analyzer and label it as the disconnecting device for the analyzer.

4.3.2 Analog output wiring

Four analog current outputs are located on the main circuit board, which is attached to the inside of the enclosure door. Figure 3-1 shows the location of the terminals, the outputs they are assigned to, and the polarity.

For best EMI/RFI protection, use shielded output signal cable enclosed in earth-grounded metal conduit.

Keep output signal wiring separate from power wiring. Do not run signal and power or relay wiring in the same conduit or close together in a cable tray.

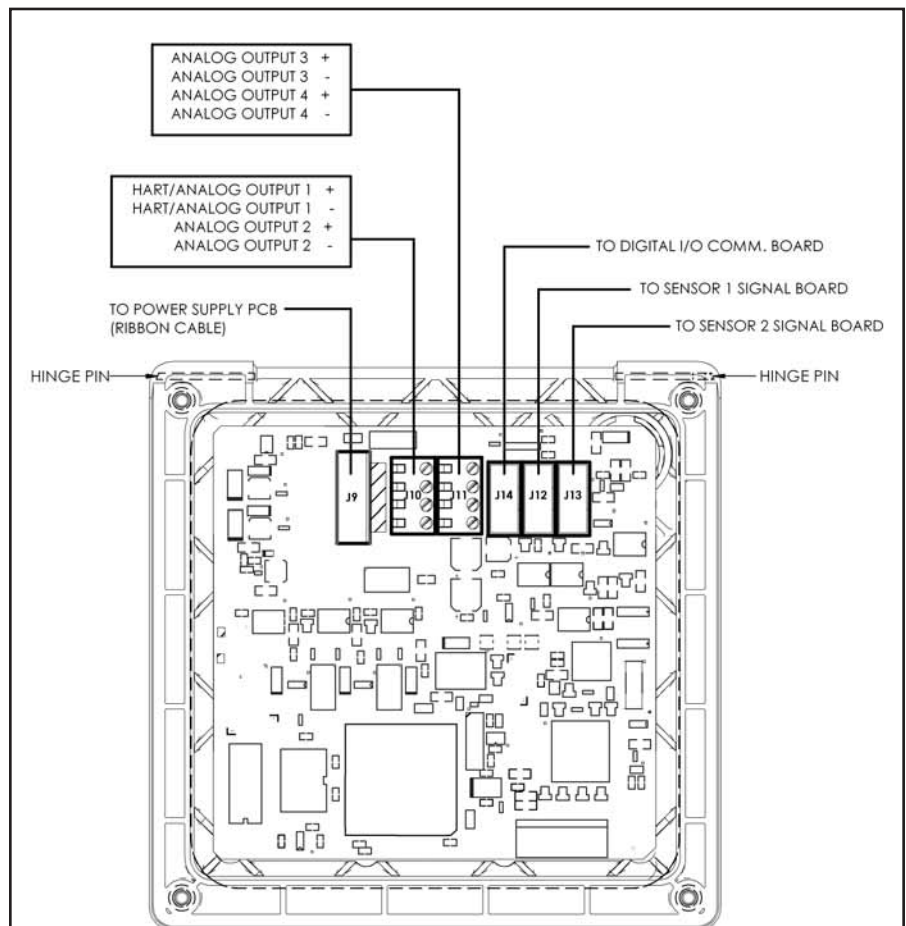


FIGURE 4-2. Analog output connections.

The analog outputs are on the main board near the hinged end of the enclosure door.

WIRING DIAGRAM		
MAIN BOARD, 1056		
B	DRAWING	REV
SIZE	40005603	A

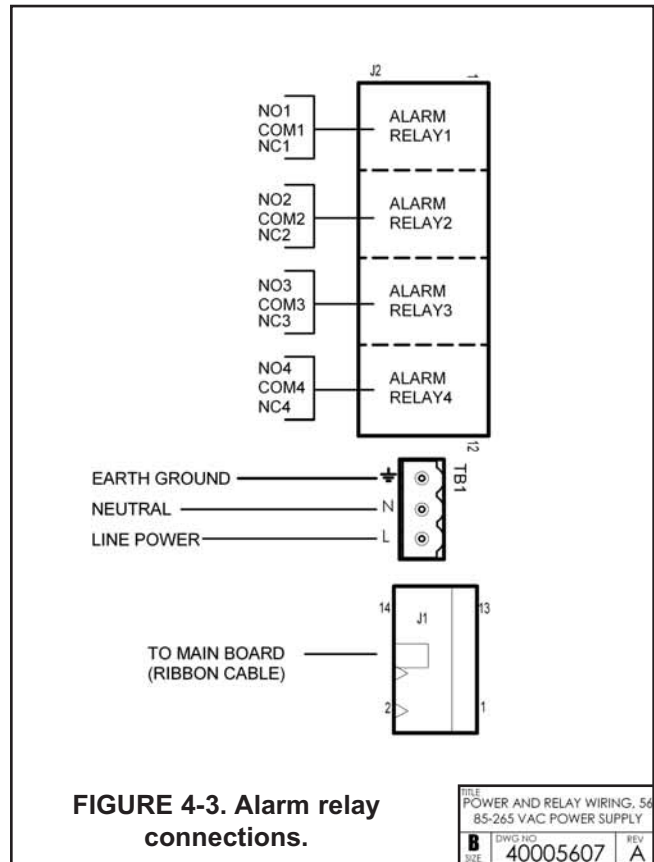
4.3.3 Alarm wiring.

⚠ WARNING
Exposure to some chemicals may degrade the sealing properties used in the following devices: Zettler Relays (K1-K4) PN AZ8-1CH12DSEA

The alarm relay terminal strip is located on the power supply board, which is mounted on the left hand side of the enclosure beneath the gray plastic cover. To remove the cover, grab it by the upper edges and pull straight out. The relay terminal strip is at the top of the board. See Figure 4-3. Bring the relay wires through the rear conduit opening on the left hand side of the enclosure and make connections to the terminal strip.

Replace the cover. The two tabs on the back edge of the cover fit into slots at the rear of the enclosure, and the three small slots in the front of the cover snap into the three tabs next to the relay terminal strip. See Figure 4-3. Once the tabs are lined up, push the cover to snap it in place.

Keep alarm relay wiring separate from signal wiring. Do not run signal and power or relay wiring in the same conduit or close together in a cable tray.

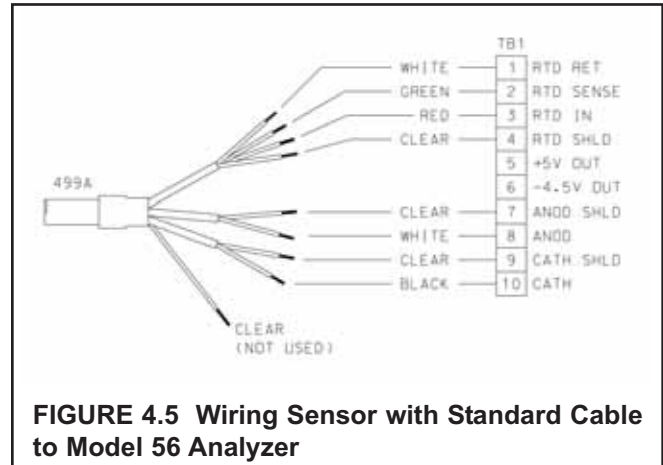
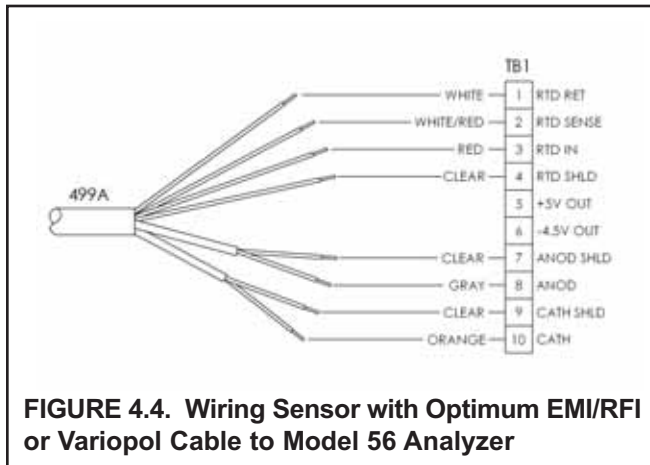


4.4 SENSOR WIRING

1. Shut off power to the analyzer.
2. Locate the chlorine signal board.

Slot 1 (left)	Slot 2 (center)	Slot 3 (right)
communication	input 1 (chlorine)	input 2 (optional)

3. Insert the sensor cable through the conduit opening nearest the chlorine board.
4. Slide the board forward to gain access to the wires and terminal screws.
5. Connect the sensor cable to the chlorine board. Refer to Figure 4-4 or 4-5.
6. Once the cable has been connected, slide the board fully into the enclosure while taking up the excess cable through the conduit opening. If you are using a cable gland, tighten the gland nut to secure the cable and ensure a sealed enclosure.



4.5 APPLY POWER TO THE ANALYZER AND COMPLETE QUICK START

1. Once all wiring connections are secured and verified, apply power to the analyzer.
2. When the analyzer is powered up for the first time, **Quick Start** screens appear. The first quick start screen has two control boxes, one for language and the other for temperature units.
 - a. The cursor, shown by dark blue backlighting, will be on the language control box. To change the language, press the ENTER/MENU key. A list of available languages, shown two at a time, will appear. Using the up and down keys, scroll (see section 4.2) to display the choices. Press ENTER/MENU to select the desired language. Press the down key to move the cursor to the temperature control box. To change units, press ENTER/MENU and scroll to either °F or °C. Press ENTER/MENU to store the selection.
 - b. To move to the next screen, use the navigation keys to move the cursor to NEXT and press ENTER/MENU.
3. The next screen lists navigation rules. Press ENTER/MENU for the next screen.
4. The next step is to configure sensor 1. Sensor 1 is the total chlorine sensor. The screen has two control boxes.
 - a. For measurement choose total chlorine.
 - b. Choose the desired units, mg/L or ppm
5. Move the cursor to NEXT and press ENTER/MENU. The display will change to show some basic keypad operation guidelines. Press ENTER/MENU to show the main display.
6. The outputs, alarms, display configuration, and data logging are all assigned to default values. The default value for data logging is disabled. To change the settings refer to Sections 6.5, 7.0, and 9.0.

SECTION 5. START-UP

NOTE

Complete Section 4 before starting this section.

5.1 PREPARE THE REAGENT

WARNING

The reagent contains potassium iodide dissolved in distilled vinegar or 5% acetic acid. Avoid contact with skin and eyes. Wash thoroughly after using.

1. **DO NOT PREPARE THE SOLUTION UNTIL READY TO USE.**
2. Position the blue plastic carboy under the sample conditioning cabinet. Unscrew the cap and reagent tube assembly.
3. Add the potassium iodide reagent to the carboy. See the table.

Expected range, ppm as Cl ₂	Amount of KI needed per 5 gal (19 L) of vinegar	Part number
0 – 5 ppm	25 grams	24164-00
0 – 10 ppm	50 grams	24164-01
0 – 20 ppm	2 x 50 grams	24164-01

4. Add five gallons (19 L) of distilled white vinegar one gallon (4 L) at a time. Swirl the carboy after each addition
5. Screw the cap on the carboy. Be sure the reagent uptake tube extends to the bottom of the carboy.
6. If it hasn't already been connected, connect the reagent tube to the small fitting on the bottom left hand side of the enclosure.

NOTE

The shelf life of the potassium iodide vinegar solution is at least two months if stored in the blue carboy. Do not store the reagent in a container other than the blue carboy. The reagent is sensitive to sunlight, which the blue carboy effectively blocks.

5.2 ZERO THE SENSOR

1. Place the sensor in a beaker of deionized water or simply place the sensor in air.
2. Let the sensor operate until the sensor current is stable, then zero the sensor. See Section 8.4.

5.3 START SAMPLE FLOW

Adjust the sample flow until a slow stream of liquid is running down the inside tube of the sampling cup.

5.4 BEGIN OPERATION AND CALIBRATE THE SENSOR

1. Turn on the reagent and sample pump switches. Observe that liquid begins to fill the flow cell. The sample flow is about 11 mL/min, so the flow cell will fill rather slowly. Also observe that the air pump is operating. The pump will produce very vigorous bubbling in the flow cell.
2. Once the flow of reagent starts, it takes about two minutes for the reagent to reach the flow cell. If the concentration of total chlorine in the sample is greater than about 0.5 ppm, the treated sample in the flow cell will be pale yellow. Sample containing more chlorine will be dark yellow.
3. Monitor the sensor current. Once the reading is stable, calibrate the unit. See Section 8.4. It may take thirty minutes or longer for the reading to stabilize when the sensor is first put in service.

SECTION 6.0 DISPLAY AND OPERATION

6.1. MAIN DISPLAY

The analyzer has a four line display. See Figure 6-1. The display can be customized to meet user requirements. See Section 6.5. Fault or warning messages, if appropriate, appear at the bottom of the screen. See Section 13.1.

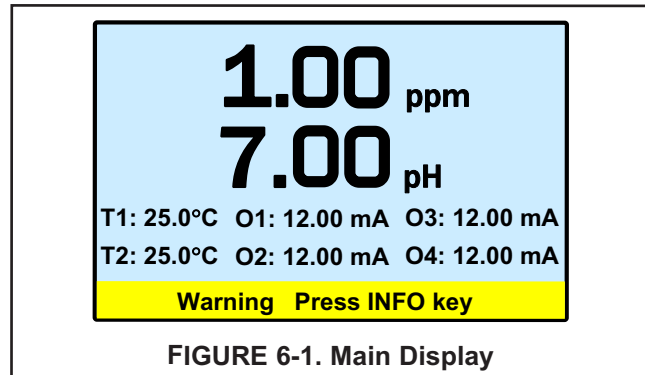


FIGURE 6-1. Main Display

The following abbreviations are used in the lower two lines of the display. The number following the abbreviation refers to the sensor, alarm relay, or output.

O	output	M	measurement
T	temperature (live)	AL	alarm relay
Tm	temperature (manual)	I	sensor current (chlorine)

6.2. KEYPAD

Local communication with the analyzer is through the membrane keypad. See Figure 6-2.

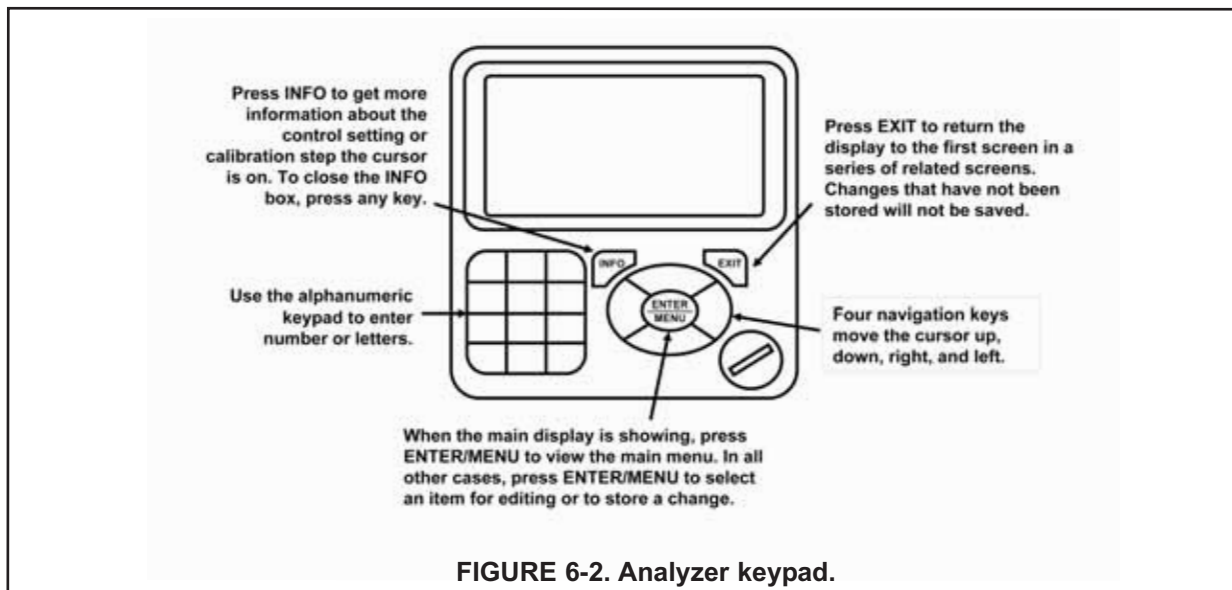


FIGURE 6-2. Analyzer keypad.

6.3 OPERATION

The operation of the Model 56 can best be understood from the following example.

S1: 1.00 ppm 25.0°C		S2: 7.00 pH 25.0°C	
Calibrate	Data storage and retrieval		
Program	HART		
Hold	Time and date		
Display setup	Reset		

1. With the main display showing (Figure 6-1), press the ENTER/MENU key. The main menu, shown at left, will appear. **Pressing the ENTER/MENU key will bring up the main menu only if the main display is showing.**

Note that the current reading and temperature for sensor 1 (S1) and sensor (S2), if applicable, always appear at the top of the screen.

The cursor (dark blue backlit field) is on the Calibrate button. Press the down key to move the cursor to the Program button.

S1: 1.00 ppm 25.0°C		S2: 7.00 pH 25.0°C	
Outputs	Relays	Measure	Temperature
Security			
Output	1		
Analog/PID/Simulate	Analog		
Assign	S1 measurement		
Range	4-20 mA		
Scale	Linear		
Dampening	0 sec		
		NEXT	BACK

2. Press the ENTER/MENU key. The cursor is on the outputs tab and the first screen in the outputs sub-menu is showing.

To select a different program submenu use the right key to move the cursor to the desired tab and press ENTER/MENU.

S1: 1.00 ppm 25.0°C		S2: 7.00 pH 25.0°C	
Outputs	Relays	Measure	Temperature
Security			
Output	1		
Analog/PID/Simulate	Analog		
Assign	S1 measurement		
Range	4-20 mA		
Scale	Linear		
Dampening	0 sec		
		NEXT	BACK

3. To enter the outputs submenu, press the down key. The cursor moves to the first control box, Output. The Model 56 has four analog outputs, and this control lets the user select which output to configure.

S1: 1.00 ppm 25.0°C		S2: 7.00 pH 25.0°C	
Outputs	Relays	Measure	Temperature
Security			
Output	1		
Analog/PID/Simulate	Analog		
Assign	S1 measurement		
Range	4-20 mA		
Scale	Linear		
Dampening	0 sec		
		NEXT	BACK

4. The default is output 1. To select a different output, press the ENTER/MENU key. A list of the available outputs, shown **two at a time**, appears. To view the list, press or press and hold the up or down key. To select and store the highlighted selection, press ENTER/MENU.

S1: 1.00 ppm 25.0°C		S2: 7.00 pH 25.0°C	
Outputs	Relays	Measure	Temperature
Security			
Output	1		
Analog/PID/Simulate	Analog		
Assign	S1 measurement		
Range	4-20 mA		
Scale	Linear		
Dampening	0 sec		
		NEXT	BACK

5. To move from one control box to another, press the up or down key.
6. Some controls require the user to select an item from a list. Others, like the dampening control, require the user to enter a number. Move the cursor to Dampening at the bottom of the screen.

S1: 1.00 ppm 25.0°C		S2: 7.00 pH 25.0°C	
Outputs	Relays	Measure	Temperature Security
Output	1 ▼		
Analog/PID/Simulate	Analog ▼		
Assign	S1 measurement ▼		
Range	4-20 mA ▼		
Scale	Linear ▼		
Dampening	sec		
		NEXT	BACK

7. The default dampening value is 0 seconds. To change the value, press ENTER/MENU. The dark blue back-lighting will disappear indicating that a number can be entered. Use the numeric keypad to enter the desired number. If you make an error, press the left key to erase the digit last entered. To store the number, press ENTER/MENU.

S1: 1.00 ppm 25.0°C		S2: 7.00 pH 25.0°C	
Outputs	Relays	Measure	Temperature Security
Dampening applies to the output only, not the main display. Increasing the dampening time reduces the noise on the output, but increases the response time.			

8. Every control box has an information or help screen associated with it. To view the information screen for the control box the cursor is on, press the INFO key. The information screen for the Dampening control is shown at left. To close the information screen, press any key.

S1: 1.00 ppm 25.0°C		S2: 7.00 pH 25.0°C	
Outputs	Relays	Measure	Temperature Security
Output	1 ▼		
Analog/PID/Simulate	Analog ▼		
Assign	S1 measurement ▼		
Range	4-20 mA ▼		
Scale	Linear ▼		
Dampening	sec		
		NEXT	BACK

9. A NEXT and BACK button are at the bottom of the screen. The NEXT button means that additional control boxes are available on at least one more screen. To view the next screen, use the navigation keys (either down or right) to move the cursor to NEXT and press ENTER/MENU.

S1: 1.00 ppm 25.0°C		S2: 7.00 pH 25.0°C	
Outputs	Relays	Measure	Temperature Security
Range: 0/4 mA	0.000 ppm		
Range: 20 mA	10.00 ppm		
Fault	Fixed ▼		
Fault current	22.00 mA		
		BACK	

10. The next screen in the Outputs sub-menu appears. The cursor is on the outputs tab. To enter the screen, press the down navigation key.

11. To return to the previous screen, move the cursor to BACK and press ENTER/MENU.

12. To return to the main menu, press EXIT.

6.4 HOLD

6.4.1 Purpose

To prevent unwanted alarms and improper operation of control systems or dosing pumps, place the alarm relays and outputs assigned to the sensor in hold before removing the sensor for maintenance. Hold is also useful if calibration, for example, buffering a pH sensor, will cause an out of limits condition. During hold, outputs assigned to the sensor remain at the last value, and alarms assigned to the sensor remain in their present state.

6.4.2 Using the Hold Function.

The hold function uses certain programming features not discussed in Section 6.3.

1. With the main display showing, press ENTER/MENU. The main menu will appear. Choose Hold. The screen shown at left appears. The cursor is on the first check box. To hold outputs and relays associated with sensor 1, press ENTER/MENU. A check will appear in the check box. To put sensor 2 on hold also, move the cursor to the sensor 2 line and press ENTER/MENU to check the sensor 2 hold box.

2. To activate Hold, move the cursor to the APPLY button at the bottom left of the screen and press ENTER/MENU. The selected sensor outputs and alarm relays will remain on hold until taken out of hold. However, if power is lost then restored, hold will automatically be turned off.

3. The screen describes how to take the analyzer out of hold. **Be sure to press APPLY once the box has been unchecked.**

4. A message stating which sensors are in hold will appear in the fault/warning banner at the bottom of the main display.

6.5 MAIN DISPLAY

6.5.1 Configuring the main display

The main display can be configured to meet specific user requirements.

1. With the main display showing, press ENTER/MENU. The main menu will appear. Choose Display Setup. The screen shown at left appears.

2. Move the cursor the Display setup tab and press ENTER/MENU. The screen shown at left appears.

3. Choose Configure main display. The screen at left appears. The position of each control box corresponds to the position of the variable in the main display. Move the cursor to the control box and press ENTER/MENU. Use the up and down keys to scroll through the list of variables and press ENTER/MENU to select the desired variable for display.

6.5.2 Setting brightness

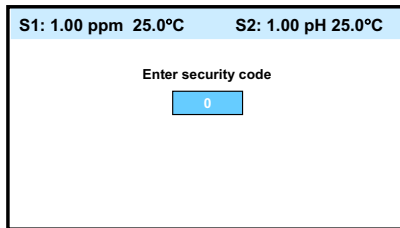
Move the cursor to the Set brightness button in the screen shown in step 2 in Section 6.5.1 and press ENTER/MENU. Then, move the cursor to the Display brightness control and select the desired brightness. The information screen gives recommendations about setting the brightness level especially in areas where the ambient temperature exceeds 121°F (50°C).

6.6 SECURITY

6.6.1 How the Security Code Works

Security codes prevent accidental or unwanted changes to program settings or calibrations. There are three levels of security.

- a. A user can view the main display and diagnostic screens only.
- b. A user has access to the calibration and hold menus only.
- c. A user has access to all menus.



1. If a security code has been programmed, pressing a sub-menu button (See section 6.3) will cause the security screen shown at left to appear.
2. Enter the three digit security code.
3. If the entry is correct, the requested sub-menu will appear and the user has access to all the sub-menus the code entitles him to.
4. If the entry is wrong, the invalid code screen appears.

6.6.1 Assigning Security Codes

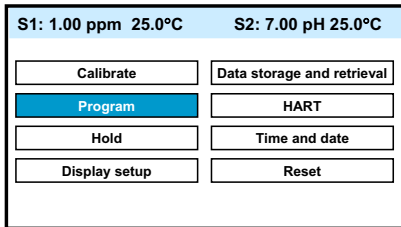
See Section 7.6.

6.6.2 Bypassing Security Codes

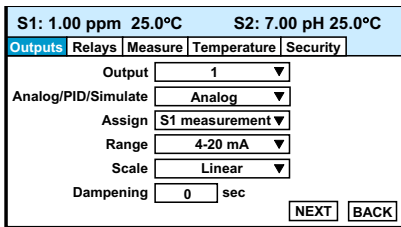
Call the factory.

SECTION 7.0 PROGRAMMING THE ANALYZER

7.1 ENTERING THE PROGRAM MENUS



1. With the main display showing, press ENTER/MENU to display the main menu. Move the cursor to Program and press ENTER/MENU.

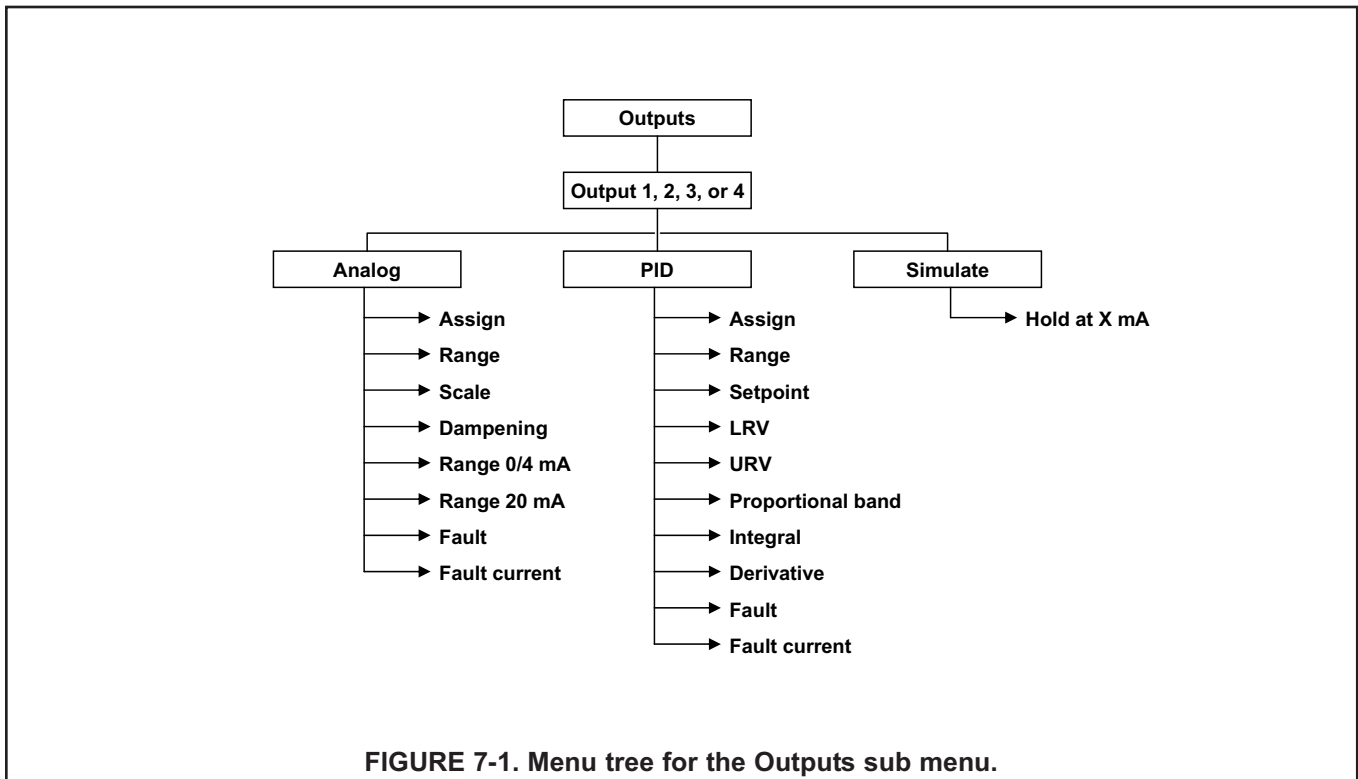


2. Move the cursor to the tab showing the desired sub menu and press ENTER/MENU. A fifth tab, not shown, labeled pH diagnostics setup, will be present if one of the sensors is a pH sensor.

7.2 OUTPUTS

7.2.1 Menu Tree

Figure 7-1 is the Outputs menu tree.



7.2.2. Settings

Move the cursor to the appropriate control box and make the desired setting. For more information about the control box the cursor is on press INFO. To close the information screen, press any key.

7.3 RELAYS

7.3.1 Menu Tree

Figure 7-2 is the Relays menu tree.

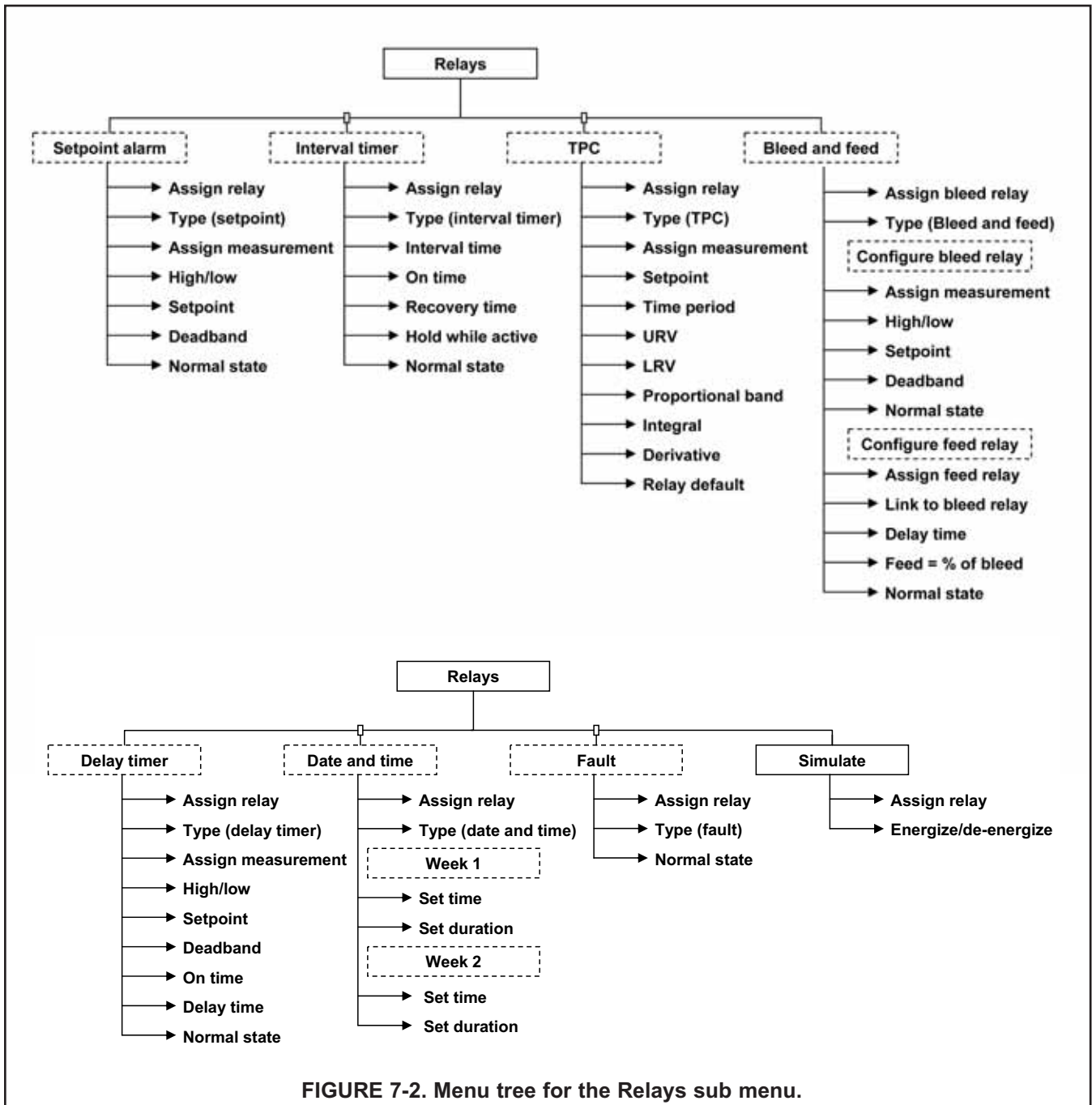


FIGURE 7-2. Menu tree for the Relays sub menu.

7.3.2. Settings

S1: 1.00 ppm 25.0°C		S2: 7.00 pH 25.0°C	
Outputs	Relays	Measure	Temperature Security
Explanation of relay actions			
Configure relay			
Simulate relay action			
BACK			

1. A large number of relay actions are available in the Model 56. For more information about a relay action, move the cursor the Explanation of relay actions button and press ENTER/MENU.

S1: 1.00 ppm 25.0°C		S2: 7.00 pH 25.0°C	
Outputs	Relays	Measure	Temperature Security
Setpoint alarm info	Delay timer info		
Interval timer info	Date and time timer info		
TPC info	Totalizer based timer info		
Bleed and feed info	Fault info		
BACK			

2. The screen at left appears. Select the desired relay action and press INFO to display the information screen. To close the information screen, press any key.

The totalizer-based relay timer is not available with the Model 56 offered as standard options with the TCL. It is available only if one of the measurements is flow.

To configure a relay, press EXIT to return to the screen in step 1.

S1: 1.00 ppm 25.0°C		S2: 7.00 pH 25.0°C	
Outputs	Relays	Measure	Temperature Security
Relay	1		
Type	Setpoint		
Assign	S1 measurement		
Logic	High		
Setpoint	10.00 ppm		
Deadband	0.00 ppm		
NEXT BACK			

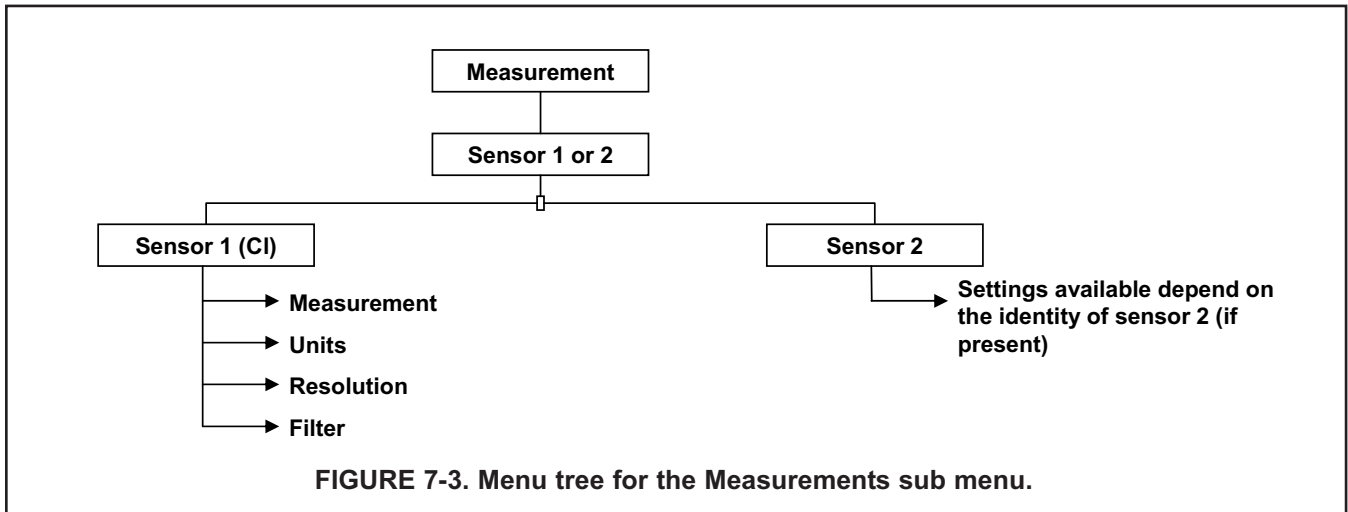
3. Move the cursor to the Configure relay button and press ENTER/MENU. A screen similar to the one at left will appear.

4. Move the cursor to the appropriate control box and make the desired setting. For more information about the control the cursor is on press INFO. To close the information screen, press any key.

7.4 MEASUREMENT

7.4.1 Menu Tree

Figure 7-3 is the Measurements menu tree.



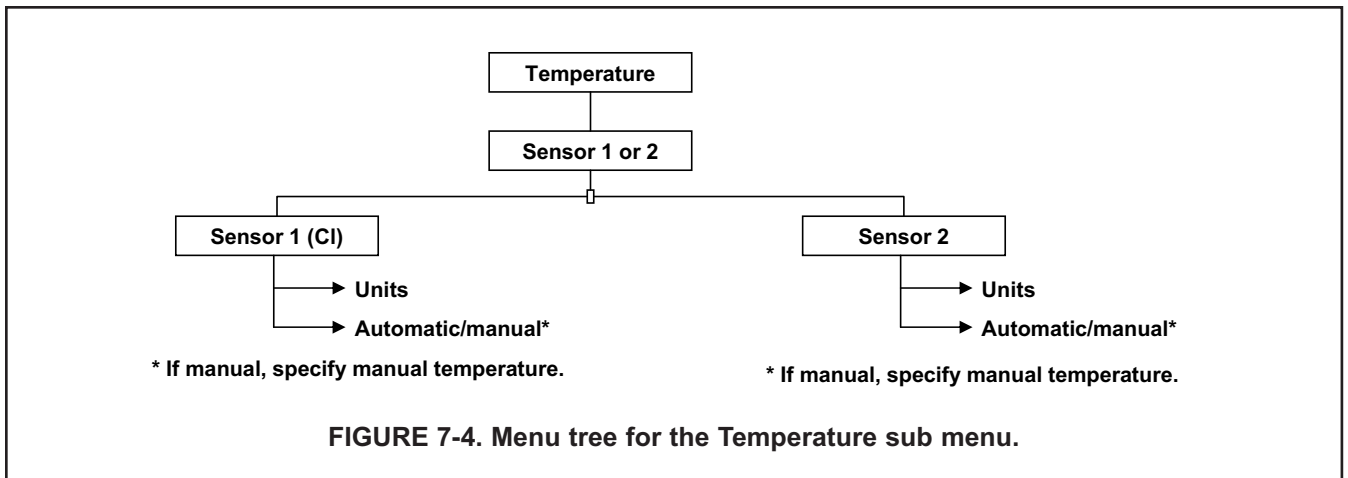
7.4.2. Settings

Move the cursor to the appropriate control box and make the desired setting. For more information about the control the cursor is on press INFO. To close the information screen, press any key.

7.5 TEMPERATURE

7.5.1 Menu Tree

Figure 7-4 is the Temperature menu tree.



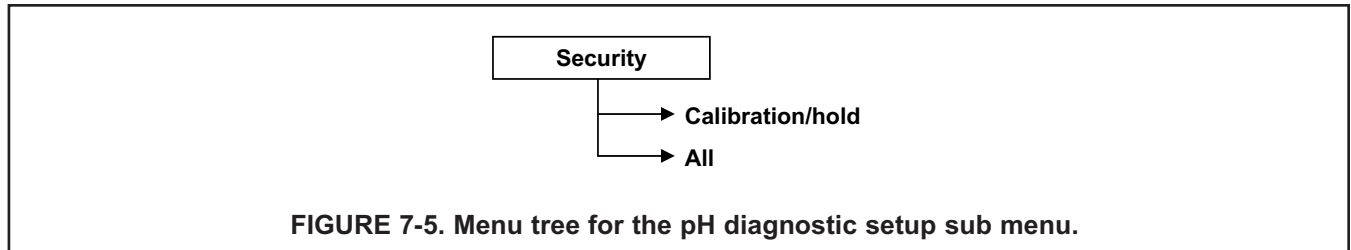
7.5.2. Settings

Move the cursor to the appropriate control box and make the desired setting. For more information about the control the cursor is on press INFO. To close the information screen, press any key.

7.6 SECURITY

7.6.1 Menu Tree

Figure 7-5 is the security setup menu tree.



7.6.2. Settings

Move the cursor to the appropriate control box and make the desired setting. For more information about the control the cursor is on press INFO. To close the information screen, press any key.

7.7 RESTORING DEFAULT SETTINGS

See section 8.6.

SECTION 8.0 CALIBRATION

8.1 INTRODUCTION

The calibrate menu allows the user to do the following:

1. Calibrate the RTD (temperature sensing element) in the chlorine and pH sensors.
2. Calibrate the chlorine sensor.
3. Calibrate the analog outputs.

8.2 ENTERING THE CALIBRATION MENUS

S1: 1.00 ppm 25.0°C		S2: 7.00 pH 25.0°C	
Calibrate	Data storage and retrieval		
Program	HART		
Hold	Time and date		
Display setup	Reset		
BACK			

1. With the main display showing, press ENTER/MENU to display the main menu. The cursor will be on Calibrate. Press ENTER/MENU.

S1: 1.00 ppm 25.0°C		S2: 7.00 pH 25.0°C	
S1 Measurement	Output 1		
S1 Temperature	Output 2		
S2 Measurement	Output 3		
S2 Temperature	Output 4		
BACK			

2. Choose the sensor (measurement or temperature) or output to be calibrated. Sensor 1 (S1) is the free chlorine sensor; sensor 2 (S2) is the pH sensor (if present).

8.3 CALIBRATING TEMPERATURE

To calibrate the temperature device in the sensor, choose S1 temperature or S2 temperature and follow the prompts. If you want more information about a calibration step, press the INFO key. Once the calibration is complete, the screen will show the results of the calibration. The screen will also show some acceptance criteria to help you determine whether to accept the calibration. Press the INFO key for an information screen to aid with troubleshooting if the calibration results are not acceptable.

8.4 CALIBRATING THE FREE CHLORINE SENSOR

S1: 1.00 ppm 25.0°C	S2: 7.00 pH 25.0°C
Why is calibration necessary? To find out press INFO. Otherwise, choose the desired calibration method.	
<input type="button" value="Zero"/>	
<input type="button" value="Grab"/>	
<input type="button" value="BACK"/>	

1. Choosing sensor 1 (total chlorine) in section 8.2 causes the screen shown at left to appear. There are two steps to calibrating a free chlorine sensor, measuring the zero current (zero) and determining the slope of the calibration curve (grab). Because stable total chlorine standards in the ppm range do not exist, the sensor must be calibrated against the results of a laboratory test run on a grab sample.

2. To zero the sensor, select Zero and follow the prompts. For more information about preparing the zero solution and measuring the zero current, press the INFO key when prompted.

If the zero step is successful, the analyzer will display the zero complete screen and the measured zero current. The screen will also show the typical zero current for the sensor and the recommended acceptance criterion. You will be asked to accept the zero current. Press the INFO key for an information screen to aid with troubleshooting if the results are not acceptable.

If the zero current is badly in error, the analyzer will display the zero failed screen. Press the INFO key for troubleshooting.

3. To calibrate the sensor response in chlorinated water, select Grab and follow the prompts. Be sure the sensor is installed in the flow cell in the TCL and the sample is flowing down the inside tube of the overflow sampler. Also, verify that reagent is being delivered to the sample and that the air pump is working.

If the calibration is successful, the analyzer will display the calibration complete screen and the sensitivity (nA/ppm). The screen will also show the typical sensitivity range for the sensor and the recommended acceptance criterion. You will be asked to accept the calibration. Press the INFO key for an information screen to aid with troubleshooting if the calibration is not acceptable.

If the sensitivity is badly in error, the analyzer will display the calibration failed screen. Press the INFO key for troubleshooting.

8.5 CALIBRATING THE ANALOG OUTPUTS

Choose the appropriate output in section 8.2 and follow the prompts to trim the selected output. If the calibration is successful the trim complete screen will appear. If the entered value is more than 1.0 mA different from the simulated output current, the analyzer will display the possible error screen, and you will be asked to accept the calibration. Press the INFO key for an information screen to aid with troubleshooting if the calibration is not acceptable.

8.6 RESET

8.6.1 Purpose

There are three resets.

1. Reset all user settings, including calibration and program settings, to the factory default values. The analyzer will return to Quick Start. **The event logger and data logger (See section 8.0) will be unaffected.**
2. Reset sensor calibration to the default value. The analyzer will clear all user-entered calibration data for the selected sensor. It will leave all other user-entered data unaffected.
3. Reset the analog output calibration for the selected output to the default value. The analyzer will leave all other user-entered settings unchanged.

8.6.2 Procedure

1. With the main display showing, press ENTER/MENU to display the main menu. Move the cursor to Reset and press ENTER/MENU.
2. Check the desired boxes and press APPLY.

SECTION 9.0 DATA AND EVENT LOGGING AND RETRIEVAL

9.1. OVERVIEW

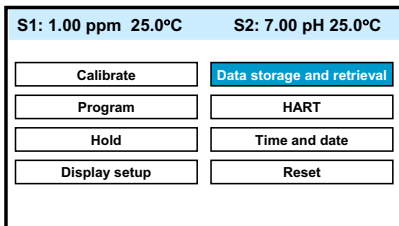
Data and event logging is a standard feature in the Model 56 analyzer. However, the feature must be enabled.

When data/event logging is enabled, the Model 56 analyzer will automatically store the following **events** with date and time stamp: faults, warnings, calibration data, calibration results (pass or fail), power on/off cycles, hold on/off, and new sensor board detected. At the user's discretion the analyzer will also store alarm activation and deactivation as events. The event logger holds 300 events. When the capacity of the logger is reached, the oldest events are removed to make room for new events.

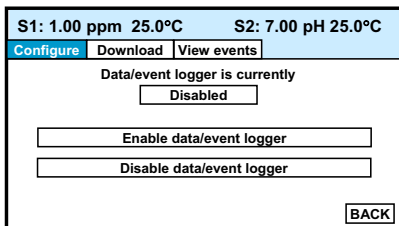
When data/event logging is enabled, the analyzer will automatically store the following measurement data for total chlorine: date and time, ppm chlorine, temperature, and sensor current.

The analyzer can store up to 30 days of data. When the capacity of the logger is reached, the oldest data are removed to make room for new data. Data storage frequency is once every 30 seconds.

9.2. CONFIGURATION



1. With the main display showing, press MENU/ENTER. Choose Data storage and retrieval



2. The screen shown at left appears. The data logger is currently disabled (default). To enable the data logger, move the cursor to the Enable data/event logger button and press ENTER/MENU.

3. Make the appropriate date and time settings and choose which alarm relay activations and deactivations to record as events.

NOTE

Setting the date or time to an earlier value than the one currently showing will cause data to be lost from the data/event logger. Download data before resetting time or date. See section 9.3.

9.3. DOWNLOADING DATA AND EVENTS

To download data or events, move the cursor to the download tab and press ENTER/MENU. Unscrew the USB port cover in the lower right hand corner of the front panel and insert a USB flash drive in the port. Press the appropriate button to download data or events. Downloading may take as long as 20 minutes. During download, the display and keypad are frozen, but all other analyzer functions continue.

Downloaded data and events are stored in a spreadsheet. There is a separate spreadsheet for every day of data. The filename for downloaded data is **dl mmddyy** or **dl ddmmyy**, depending on the date and time format selected by the user. The filename for downloaded events is **el mmddyy** or **el ddmmyy**.

9.4. VIEWING EVENTS

The event log can be viewed on the Model 56 display. Move the cursor the View events tab and press ENTER/MENU. Move the cursor to the View Events button and press ENTER/MENU.

To scroll through the list of events move the cursor to the DOWN or UP key at the bottom of the screen and press and hold ENTER/MENU.

9.5. DATE AND TIME

The date and time can also be reset from the main menu by pressing the Time and Date button.

NOTE

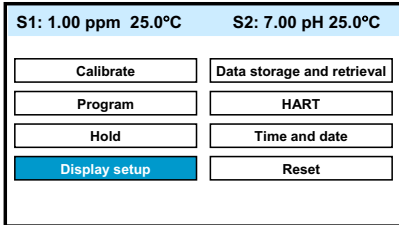
Setting the date or time to an earlier value than the one showing will cause data to be lost from the data/event logger. Download data before resetting time or date. See section 9.3.

SECTION 10.0 GRAPHICAL DISPLAY

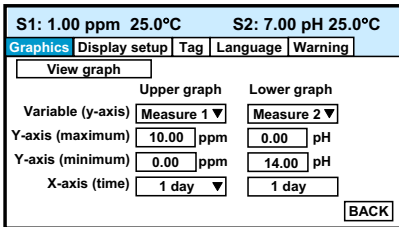
10.1. OVERVIEW

The Model 56 has a dual graphical display. Each graph can be configured to meet user requirements, although the time axis on both graphs must be the same. The time scale can be one hour, one day, seven days, or 30 days.

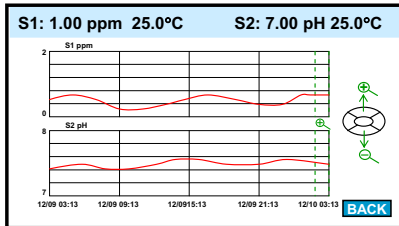
10.2. CONFIGURATION



1. With the main display showing, press MENU/ENTER. Choose Display setup.



2. The screen shown at left appears. Configure the displayed variable, the maximum and minimum values for the y-axis, and the time scale. To view the graphs, move the cursor to the View graph button and press ENTER/MENU.



3. The time axis can be expanded or shrunk. To expand the time scale, use the left or right navigation keys to move the pair of dotted green lines to the area of interest. Press the up navigation key to expand the graph. To shrink the time axis, press the down navigation key.

SECTION 11. DIGITAL COMMUNICATIONS

The Model 56 analyzer supplied with the TCL has HART communications as a standard feature and Profibus DP as an option. For more information refer to the Model 56 HART or Profibus DP Addendum Manuals.

SECTION 12. MAINTENANCE

12.1 ANALYZER

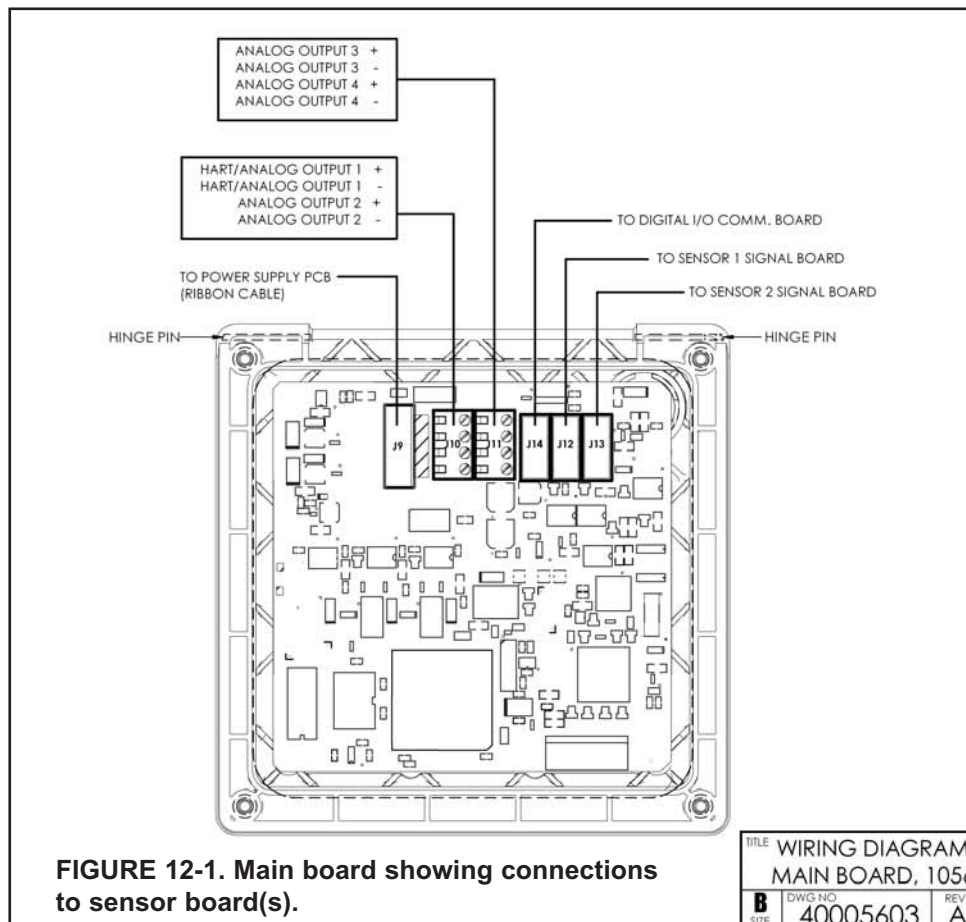
The Model 56 analyzer used with the TCL needs little routine maintenance.

Clean the analyzer case and front panel by wiping with a clean soft cloth dampened with water ONLY. Do not use solvents, like alcohol, that might cause a buildup of static charge.

The chlorine sensor circuit board (PN 24203-01) is replaceable. If you have a dual input analyzer, consult the Model 56 instruction manual for the part number of the other board.

To replace the board

1. Turn off power to the analyzer.
2. Loosen the four screws holding the front panel in place and let the front panel drop down.
3. Loosen the gland fitting and carefully push the sensor cable up through the fitting as you pull out the circuit board.
4. Once you have access to the terminal strip, disconnect the sensor.
5. Unplug the sensor board from the main board. See Figure 12.1.
6. Slide the replacement board partially into the board slot. Plug the sensor board into the main board and reattach the sensor wires.
7. Carefully pull the sensor cable through the gland fitting as you push the sensor board back into the enclosure.
8. Close the front panel.
9. Turn on power.



12.2 TOTAL CHLORINE SENSOR

12.2.1 General

When used in clean water, the total chlorine sensor requires little maintenance. Generally, the sensor needs maintenance when the response becomes sluggish or noisy or when readings drift follow calibration. Maintenance frequency is best determined by experience. If the sensor is used in potable water, expect to clean the membrane every month and replace the membrane and electrolyte solution every three months. Sensors used in dirty water require more frequent maintenance and calibration. However, if experience shows the sensor is holding calibration and not drifting appreciably between calibration intervals, the maintenance interval can be extended.

12.2.2 Cleaning the membrane.

Keep the membrane clean. Clean the membrane with water sprayed from a wash bottle. Use a soft tissue to **gently** wipe the membrane.

12.2.3 Replacing the membrane.

1. Hold the sensor with the membrane facing up.
2. Unscrew membrane retainer. Remove the membrane assembly and O-ring. See Figure 12-2.
3. Inspect the cathode. If it is tarnished, clean it by gently rubbing in the direction of the existing scratches (do not use a circular motion) with 400-600 grit silicon carbide finishing paper. Rinse the cathode thoroughly with water.
4. Prepare a new membrane. Hold the membrane assembly with the cup formed by the membrane and membrane holder pointing up. Fill the cup with electrolyte solution. Set aside.
5. Put a new O-ring in the groove.
6. Place a drop of electrolyte solution on the cathode. Invert the membrane assembly and place it over the cathode stem.
7. Screw the membrane retainer back in place.
8. Hold the sensor with the membrane pointing down. Shake the sensor a few times, as though shaking down a clinical thermometer.

12.2.4 Replacing the membrane and electrolyte solution.

 **CAUTION**

Fill solution may cause irritation. Avoid contact with skin and eyes. May be harmful if swallowed.

1. Unscrew the membrane retainer and remove the membrane assembly and O-ring. See Figure 12-2.
2. Hold the sensor over a container with the cathode pointing down.
3. Remove the fill plug and allow the electrolyte solution to drain out.
4. Wrap the plug with two turns of pipe tape and set aside. Remove old tape first.
5. Prepare a new membrane. Hold the membrane assembly with the cup formed by the membrane and membrane holder pointing up. Fill the cup with electrolyte solution. Set aside.
6. Hold the sensor at about a 45-degree angle with the cathode end pointing up. Add electrolyte solution (PN 9210438) through the fill hole until the liquid overflows. Tap the sensor near the threads to release trapped air bubbles. Add more electrolyte solution if necessary.
7. Place the fill plug in the electrolyte port and begin screwing it in. After several threads have engaged, rotate the sensor so that the cathode is pointing up and continue tightening the fill plug. Do not overtighten.
8. Place a new O-ring in the groove around the cathode post. Cover the holes at the base of the cathode stem with several drops of electrolyte solution.
9. Insert a small **blunt** probe, like a toothpick with the end cut off, through the pressure equalizing port. See Figure 12-2.

NOTE

Do not use a sharp probe. It will puncture the bladder and destroy the sensor.

Gently press the probe against the bladder several times to force liquid through the holes at the base of the cathode stem. Keep pressing the bladder until no air bubbles can be seen leaving the holes. Be sure the holes remain covered with electrolyte solution.

10. Place a drop of electrolyte solution on the cathode, then place the membrane assembly over the cathode. Screw the membrane retainer in place.
11. The sensor may require several hours operating at the polarizing voltage to equilibrate after the electrolyte solution has been replenished.

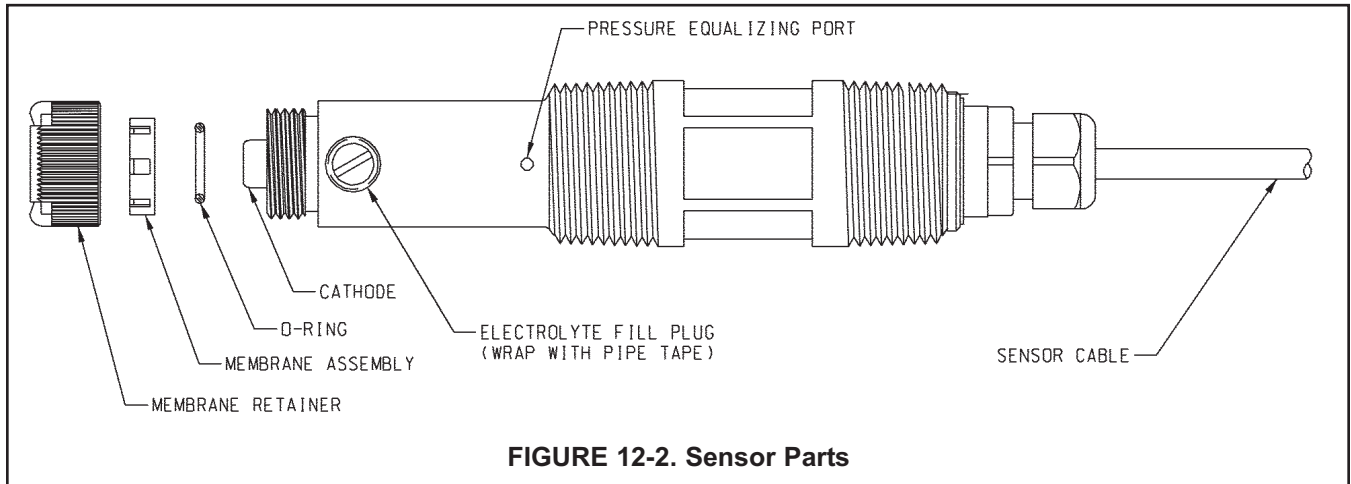


TABLE 12-1. Spare Parts

33523-00	Electrolyte Fill Plug
9550094	O-Ring, Viton 2-014
33521-00	Membrane Retainer
23501-02	Total Chlorine Membrane Assembly: includes one membrane assembly and one O-ring
23502-02	Total Chlorine Membrane Kit: includes 3 membrane assemblies and 3 O-rings
9210438	Total Chlorine Sensor Fill Solution, 4 oz (120 mL)

12.3 SAMPLE CONDITIONING SYSTEM

12.3.1 Reagent

The sample conditioning reagent lasts about 2 months. Before putting fresh reagent in the carboy, discard any small amount of remaining reagent. To prepare the reagent refer to the procedure in Section 5.1. See Table 12-2 for ordering information.

12.3.2 Sample and reagent tubing.

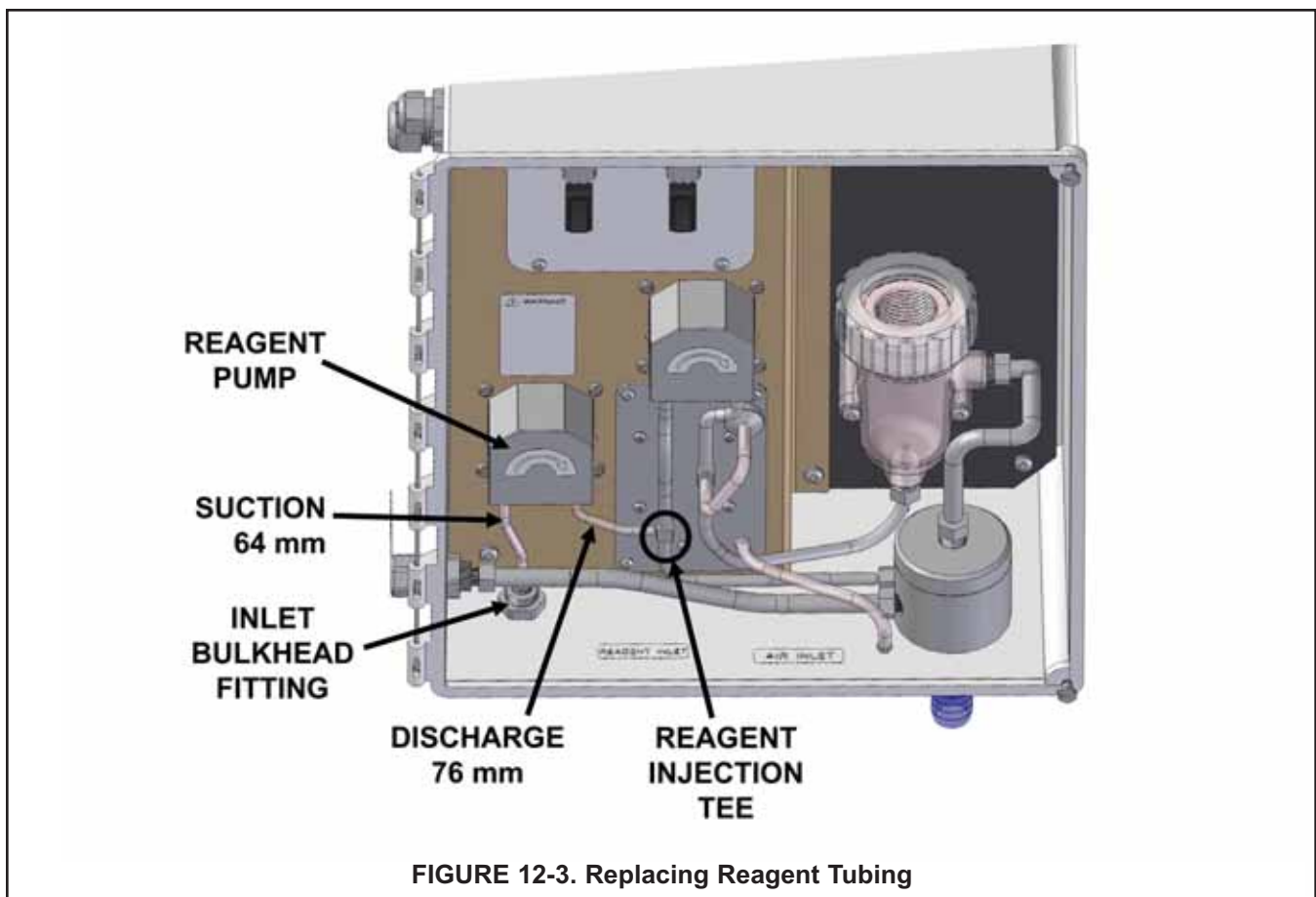
Periodically inspect sample and reagent tubing for cracks and leaks. Replace tubing if it is damaged.

After a period of time, the sample tubing may become plugged with suspended matter. The tubing is flexible and difficult to clean mechanically. Plugged sample tubing is best replaced.

Replacement tubing kits are available. See Table 12-2 for part numbers.

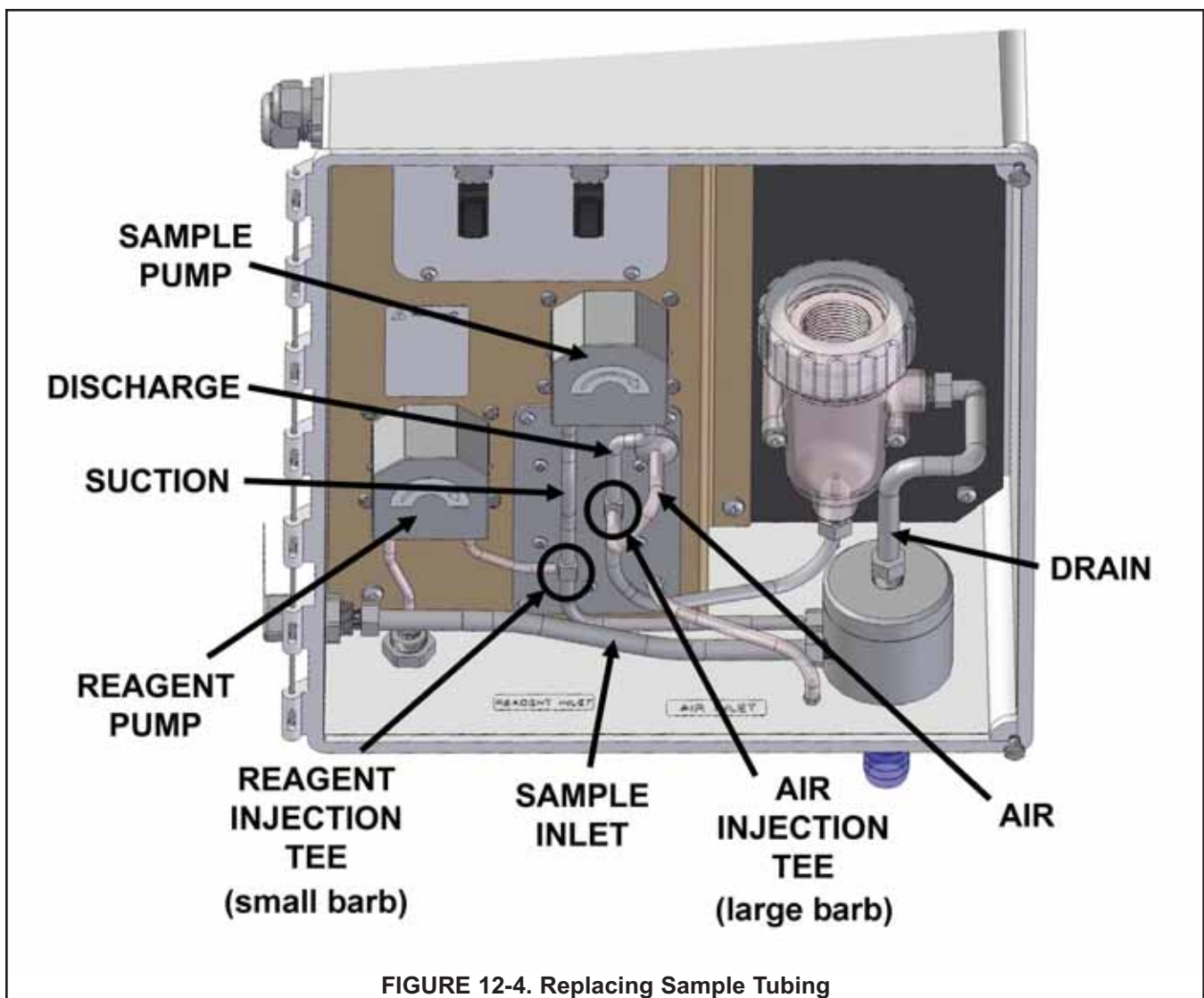
To replace reagent tubing:

1. Reagent tubing is shown in Figure 12-2.
2. Turn off sample and reagent pumps.
3. Luer fittings connect the reagent tubing to the pump. Disconnect the tubing by turning the fitting in the direction of the arrows shown in Figure 12-5.
4. Disconnect the other end of the suction tubing from the barb on the reagent inlet fitting in the bottom of the enclosure. Disconnect the other end of discharge tubing from the reagent injection tee.
5. Install the replacement tubing. Note that the discharge tubing is longer than the suction tubing.



To replace sample tubing:

1. Sample tubing and tees are shown in Figure 12-4.
2. Turn off the sample and reagent pumps.
3. Luer fittings connect the sample tubing to the pump. Disconnect the tubing by turning the fitting in the direction of the arrows shown in Figure 12-5.
4. Disconnect the other end of the sample pump suction tubing from the overflow sampler. Pull the reagent injection tubing off the reagent injection tee.
5. Disconnect the other end of the sample pump discharge tubing from the flow cell. Pull the air injection tubing off the air injection tee.
6. Disconnect the sample inlet and drain tubing.
7. Install the replacement sample pump suction and discharge tubing assemblies. The assemblies look similar. To tell the difference, note the air injection tee in the discharge tubing assembly has a larger diameter barb than the reagent injection tee in the suction tubing assembly.
8. Install replacement sample inlet and drain tubing. The sample inlet tubing is longer than the drain tubing.



12.3.3 Peristaltic pump tubing.

The expected life of the peristaltic pump tubing is one year.

To replace pump tubing:

1. Turn off the sample and reagent pumps.
2. The reagent and sample tubing is connected to the pump tubing with luer fittings. See Figure 12-5. Disconnect the fittings from the pump by turning the fitting in the direction of the arrow.

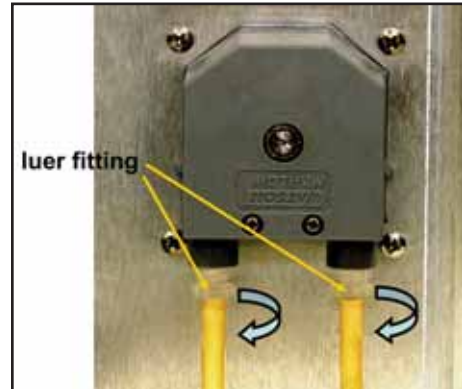


FIGURE 12-5.

3. Using your thumb and forefinger gently pinch the sides of the pump cover. Slide the cover upwards to remove it. See Figure 12-6.



FIGURE 12-6.

4. Using your thumb as shown in Figure 12-7, push the tubing fitting straight outward until the fitting slides out of the socket. Repeat the process for the other fitting.

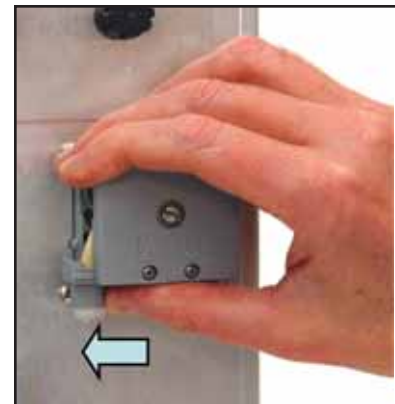


FIGURE 12-7.

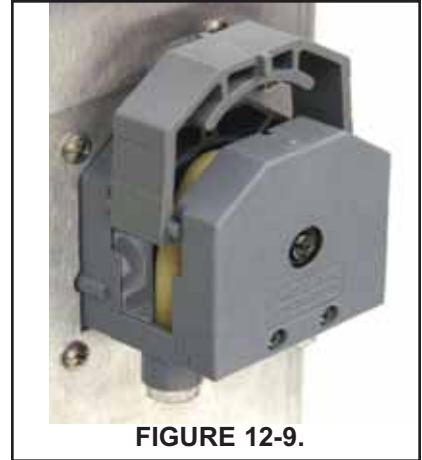
5. Remove and discard the pump tubing.

6. Insert the new tubing one end at a time. Tongues on the sides of the gray fittings at the ends of the tube fit into receiving grooves in the pump casing. See Figure 12-8. Push the fitting into place until it clicks. Gently stretch the tubing over the rollers and insert the other fitting into the receiving socket on the other side of the pump.

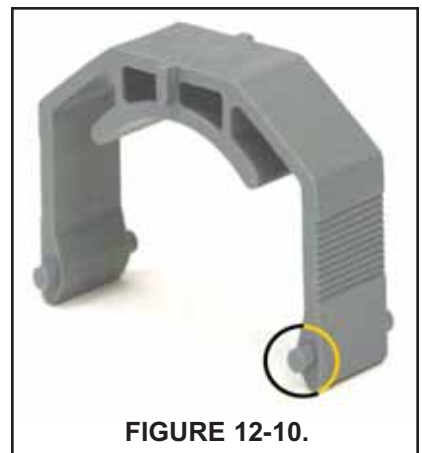


FIGURE 12-8.

7. Replace the pump cover.
 - a. Place the cover on the pump casing. See Figure 12-9.



- b. Be sure the pins at the bottom of the cover (Figure 12-10) ride on the tracks in the pump casing.



- c. The position of the track is outlined in Figure 12-11. The pins on the pump cover must ride in these tracks as the cover is pushed into place. Gently squeeze the ends of the cover to guide the pins.



- d. Push down until the cover snaps into place.

8. Reconnect the tubing.

12.3.4 Replacing the air pump

1. Disconnect power to the analyzer.
2. Refer to Figure 12-12. Disconnect the reagent and air injection tubes. Disconnect the suction and discharge tubing by turning the Luer fitting in the direction shown in the figure. Disconnect the air pump inlet tubing from the barbed fitting in the bottom of the enclosure.
3. Remove the four screws (circled in Figure 12-13) holding the air pump access panel. Pull out the pump and panel.
4. Disconnect the air inlet and outlet tubing from the air pump. See Figure 12-14.
5. Remove the five screws (surrounded by squares in Figure 12-13) holding the air pump to the access panel.
6. Remove the four screws holding the wiring access panel.
7. Disconnect the air pump power wires from the terminal strip. See Figure 12-15. Discard the old air pump.
8. Remove the five screws holding the rubber base of the replacement air pump to the body.
9. Using the five screws removed in step 6, attach the replacement air pump to the access panel.
10. Connect the air pump power wires to the terminal strip.
11. Replace the wiring access panel.
12. Connect the air inlet and outlet tubing to the air pump. See Figure 12-14. The conical end of the check valve points in the direction of the air flow.
13. Replace the air pump access panel.
14. Connect the sample pump tubing to the pump. Connect the reagent and air injection tubing. Connect the air inlet tubing to the barbed fitting at the bottom of the enclosure.

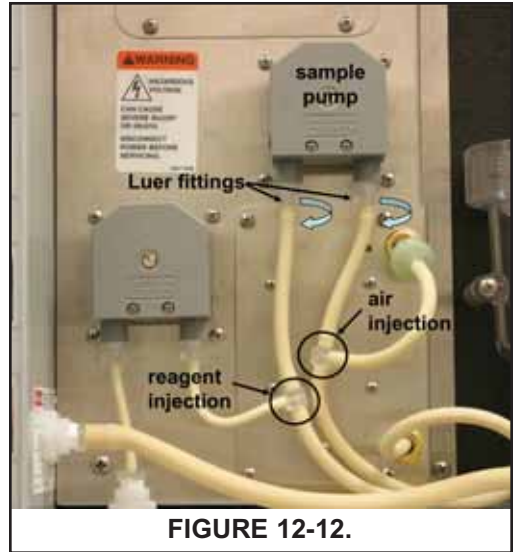
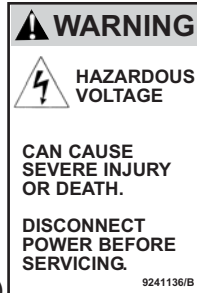


FIGURE 12-12.

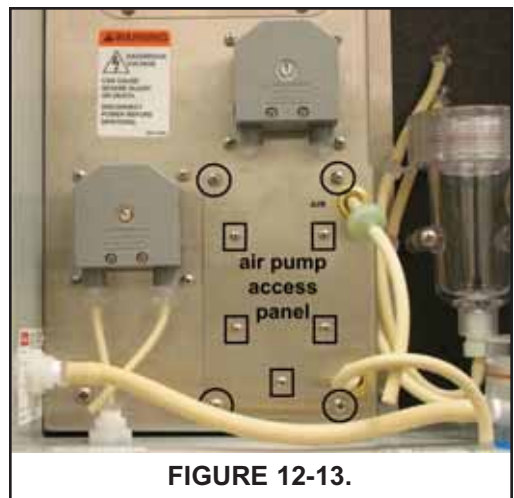


FIGURE 12-13.

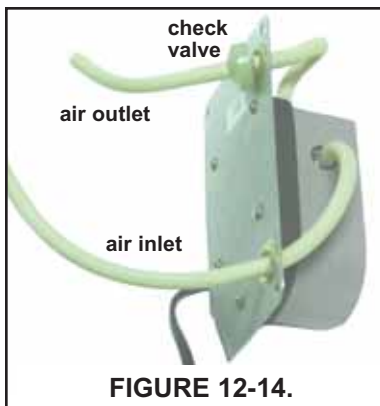


FIGURE 12-14.

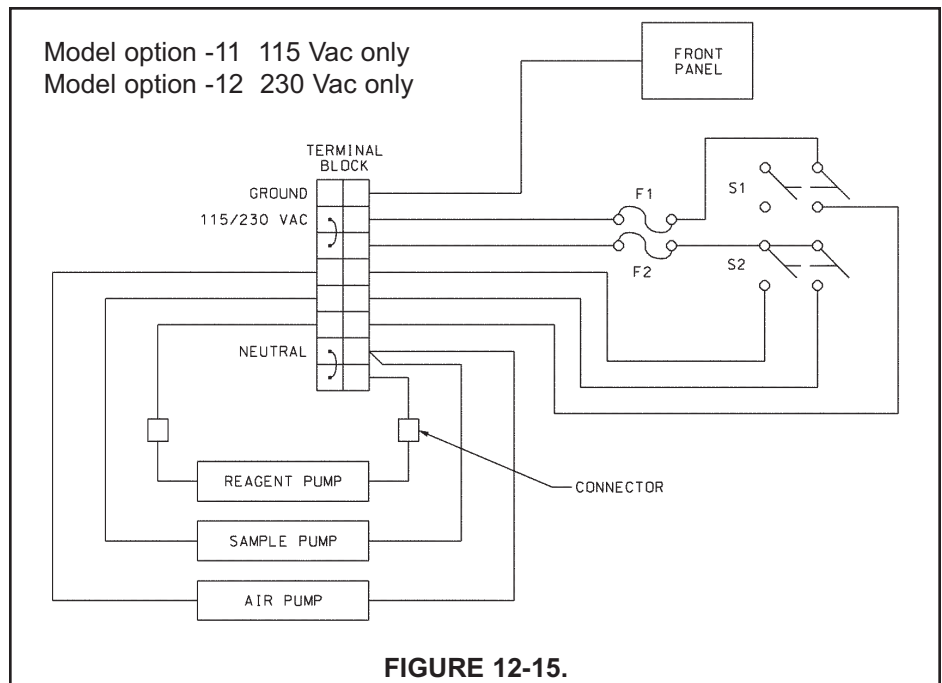


FIGURE 12-15.

12.3.5 Replacing the air pump diaphragm and check valves.

1. Disconnect power to the analyzer.
2. Refer to Figure 12-12. Disconnect the reagent and air injection tubes. Disconnect the suction and discharge tubing by turning the Luer fitting in the direction shown in the figure. Disconnect the air pump inlet tubing from the barbed fitting in the bottom of the enclosure.
3. Remove the four screws (circled in Figure 12-13) holding the air pump access panel. Pull out the pump and panel.
4. Disconnect the air inlet and outlet tubing from the air pump. See Figure 12-14.
5. Remove the five screws (surrounded by squares in Figure 12-13) holding the air pump to the access panel.
6. Pull the rubber base off the pump.
7. Using needle nose pliers, remove the air inlet fitting from the side of the air pump. See Figure 12-16.
8. Slide the pump assembly out of the air pump body. See Figure 12-17.
9. Following instructions on the package (PN 9160518), replace the diaphragm and check valves.
10. Slide the pump assembly back into the pump body and replace the barbed inlet fitting.
11. Replace the rubber base and screw the pump access panel back onto the air pump.
12. Connect the air inlet and outlet tubing to the air pump. See Figure 12-14. The conical end of the check valve points in the direction of the air flow.
13. Replace the air pump access panel.
14. Connect the sample pump tubing to the pump. Connect the reagent and air injection tubing. Connect the air inlet tubing to the barbed fitting at the bottom of the enclosure.

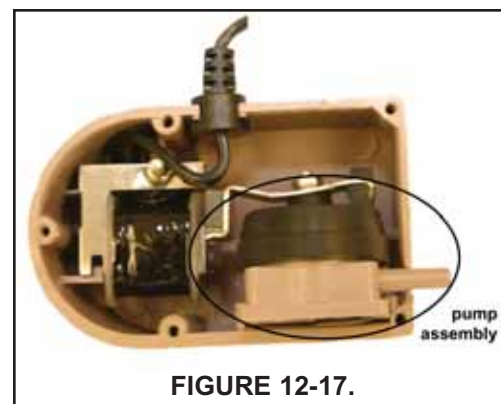
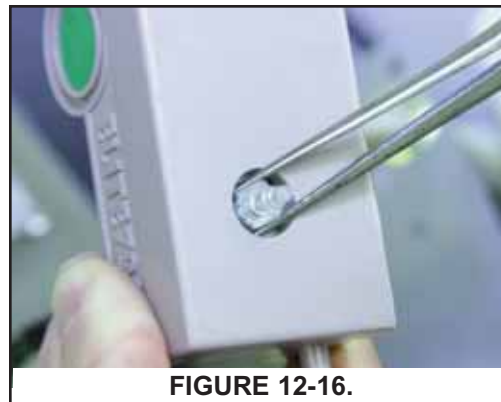
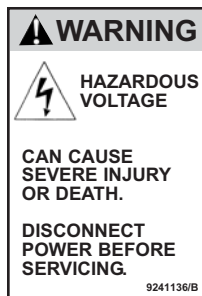


TABLE 12-2. Replacement Parts and Reagent for Sample Conditioning System

PN	Description
24134-00	Air pump, 115 Vac, 60 Hz
24134-01	Air pump, 230 Vac, 50 Hz
9160578	Air pump repair kit
9322052	Check valve for air injection line
24153-00	Carboy for reagent, 5 gal/19 L, includes cap
9100204	Fuse, 0.25 A, 250 V, 3AG, slow blow for option -11 (115 Vac)
9100132	Fuse, 0.125 A, 250 V, 3AG, slow blow for option -12 (230 Vac)
9380094	Reagent pump, 115 Vac, 50/60 Hz
9380095	Reagent pump, 230 Vac, 50/60 Hz
9380091	Reagent pump replacement tubing
24151-00	Reagent tubing replacement kit (see Section 12.3.2)
24135-00	Reagent uptake tubing, 6 ft (1.8 m), includes weight
9380090	Sample pump, 115 Vac, 50/60 Hz
9380093	Sample pump, 230 Vac, 50/60 Hz
9380092	Sample pump replacement tubing
24152-00	Sample tubing replacement kit (includes tees, see Section 12.3.2)

PN	Description
24165-00	Acetic acid, 2 x 2.5 gal (9.5 L) bottles/case, with 25 g potassium iodide
24165-01	Acetic acid, 2 x 2.5 gal (9.5 L) bottles/case, with 50 g potassium iodide
24164-00	Potassium iodide, 25 g, sufficient for 5 gallons (19 L) of vinegar (for 0-5 ppm total chlorine)
24164-01	Potassium iodide, 50 g, sufficient for 5 gallons (19 L) of vinegar (for 0-10 ppm total chlorine)

SECTION 13. TROUBLESHOOTING

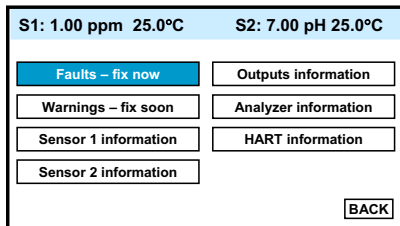
13.1 OVERVIEW

The analyzer continuously monitors itself and the sensor(s) for problems. When the analyzer identifies a problem, the word **warning** or **fault** appears intermittently at the bottom of the display. To read the fault or warning message and troubleshooting information, press INFO. See section 13.2.

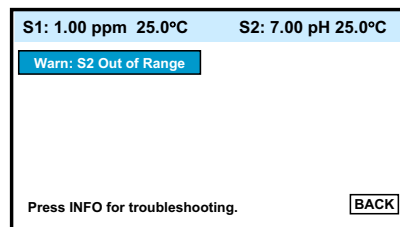
A **warning** means the instrument or sensor is usable, but steps should be taken as soon as possible to correct the condition causing the warning. Warning messages can be turned off. To turn off warning messages, go to the main menu and choose Display setup. Scroll to the Warning tab and turn off warning messages.

A **fault** means the measurement is seriously in error and is not to be trusted. A fault condition might also mean that the analyzer has failed. Fault conditions should be corrected immediately. When a fault occurs, the analog output goes to 22.00 mA or to the value programmed in Section 7.2. Fault messages cannot be turned off.

13.2 READING AND TROUBLESHOOTING FAULT AND WARNING MESSAGES



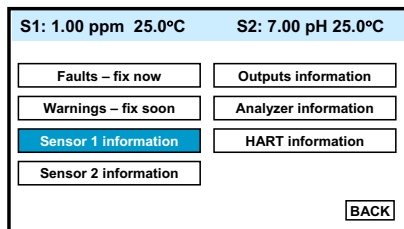
1. With the main display showing, press the INFO key. The screen at left appears. Move the cursor to the appropriate button and press ENTER/MENU.



2. A screen like the one at left will appear showing all the warning or fault messages. For troubleshooting information press the INFO key

13.3 SENSOR DIAGNOSTICS

Sensor diagnostic readings are often useful in troubleshooting measurement problems.



1. With the main display showing, press the INFO key. Move the cursor to the Sensor 1 or Sensor 2 information button and press ENTER/MENU.

2. A list of sensor diagnostics will appear. For more information about a specific diagnostic measurement, move the cursor to the diagnostic of interest and press the INFO key.

13.4 TROUBLESHOOTING CALIBRATION PROBLEMS

If a calibration attempt results in an error or a likely error, the analyzer will display the appropriate warning screen. For troubleshooting suggestions, press the INFO key.

13.5 OTHER TROUBLESHOOTING

Problem	See Section
Readings are too low	11.5.1
Process readings are erratic or wander	11.5.2
Readings drift	11.5.3
Readings are too high	11.5.4

13.5.1 Readings are low

1. Does the reagent carboy contain reagent? Is the reagent uptake tubing below the level of the reagent? Has potassium iodide been added to the acetic acid (vinegar) reagent?
2. Is there adequate flow to the overflow sampler? Excess sample should be flowing down the inside tube of the overflow sampler.
3. Does the reagent contain the correct amount of potassium iodide? See the table.

Expected range, ppm as Cl ₂	Amount of KI needed per 5 gallons of vinegar	Part number
0 – 5 ppm	25 grams	24164-00
0 – 10 ppm	50 grams	24164-01
0 – 20 ppm	2 x 50 grams	24164-01

4. Was the comparison or calibration sample tested as soon as it was taken? Chlorine solutions can be unstable. Test the sample immediately after collecting it. Avoid exposing the sample to sunlight.
5. Is the membrane fouled or coated? A dirty membrane inhibits diffusion of iodine through the membrane, reducing sensor current. Clean the membrane by rinsing it with a stream of water from a wash bottle. Wipe gently with a soft tissue.

6. Are the reagent and sample pumps running? If a pump is not running, check the fuse and replace it if necessary. See Table 12-2 for part numbers. If the fuse is okay, replace the pump.
7. Are all tube fittings tight? Pay particular attention to the luer fittings that connect the tubing to the pumps.
8. Does the pump tubing element need replacing? Remove the tubing from the pump and inspect it. If the tubing appears permanently pinched or deformed, replace the tubing. Refer to Section 12.3.3 for instructions on how to remove and replace the tubing elements. The expected life of a tubing element is about one year.
9. Is the sample flow to the sensor about 11 mL/min? If the sample flow is too low, the total chlorine reading will be low. If the flow is too high, the ratio between the sample flow and reagent flow will be too high, and there might be insufficient reagent to properly react with the total chlorine in the sample. To check sample flow...
 - a. Turn off the reagent and sample pumps.
 - b. Disconnect the luer fitting on the discharge of the sample pump. See **A** in Figure 13-1.
 - c. Hold a small beaker under the discharge port.
 - d. Start the sample pump and collect sample for two minutes.
 - e. Measure the volume of sample collected in the beaker. After two minutes, the volume should be about 22 mL.
10. Is the reagent flow about 0.2 mL/min? If the reagent flow is too low, there might be insufficient acetic acid to lower the sample pH and insufficient potassium iodide to react with total chlorine in the sample. To check reagent flow...
 - a. Turn off the reagent and sample pumps.
 - b. Disconnect the reagent tubing at the injection tee. See **B** in Figure 13-1.
 - c. Place the end of the tubing in a 5 mL graduated cylinder.
 - d. Start the reagent pump and collect reagent for ten minutes.
 - e. Note the volume of reagent collected in the graduated cylinder. After ten minutes the volume should be about 2 mL.

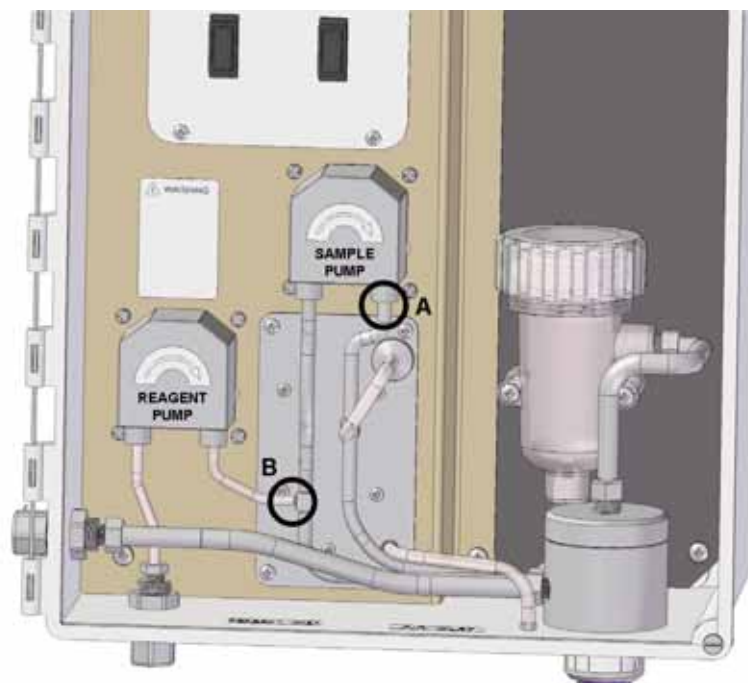


FIGURE 13-1. Disconnecting sample (A) and reagent (B) tubing prior to checking flow.

13.5.2 Process readings are erratic or wander

1. Is the sensor properly wired to the analyzer? See Section 4.3. Verify that all connections are tight.
2. Readings can be erratic when a new sensor is first placed in service. Readings usually stabilize after about an hour.
3. Is the air pump working? There should be a vigorous stream of bubbles in the flow cell. The bubbles help mix the sample and keep carbon dioxide bubbles off the membrane. Carbon dioxide forms when bicarbonate alkalinity in the sample reacts with acetic acid. The bubbles accumulate on the membrane and eventually break away, causing the total chlorine reading to wander.
4. Is the membrane damaged or loose? Replace the membrane if necessary.
5. Is the space between the membrane and cathode filled with electrolyte solution and is the flow path between the electrolyte reservoir and membrane clear? Often the flow of electrolyte can be started by simply holding the sensor with the membrane end pointing down and sharply shaking the sensor a few times as though shaking down a clinical thermometer. If shaking does not work, try clearing the holes around the cathode stem. Hold the sensor with the membraned end pointing up. Unscrew the membrane retainer and remove the membrane assembly. Use the end of a straightened paper clip to clear the holes at the base of the cathode stem.

13.5.3 Readings drift

1. Is the sample temperature changing? Membrane permeability is a function of temperature. The time constant for the 499ACL-01 sensor is about five minutes. Therefore the reading may drift for a while after a sudden temperature change.
2. Is the membrane clean? For the sensor to work properly, iodine must diffuse freely through the membrane. A coating on the membrane will interfere with the passage of iodine, resulting in a gradual downward drift in readings. The coating will also slow the response on the sensor to step changes. Clean the membrane by rinsing it with a stream of water from a wash bottle. Wipe the membrane with a soft tissue.
3. Is the sensor new or has it recently been serviced? New or rebuilt sensors may require several hours to stabilize.
4. Is the flow of sample past the sensor about 11 mL/min? See Section 13.5.1 step 9 for more information.
5. Is the reagent flow about 0.2 mL/min? See Section 13.5.1 step 10 for more information.

13.5.4 Readings are too high

1. Is the sample conditioning reagent clear and colorless? If the reagent is pale yellow, results will be high. The pale yellow color is caused by iodine, which comes from the reaction between atmospheric oxygen and potassium iodide. The reaction is catalyzed by sunlight. The purpose of the blue carboy is to protect the reagent from sunlight.
2. Is the sensor fill solution fresh? An old, discolored fill solution may produce a high reading.

13.6 OTHER TROUBLESHOOTING — GENERAL

Problem	See Section
Current output is too low	13.6.1
Alarm relays do not operate properly	13.6.2

13.6.1 Current Output Is Too Low.

Load resistance is too high. Maximum is 550Ω.

13.6.2 Alarm Relays Do Not Operate Properly

1. Verify the relays are properly wired.
2. Verify the relays are properly configured.

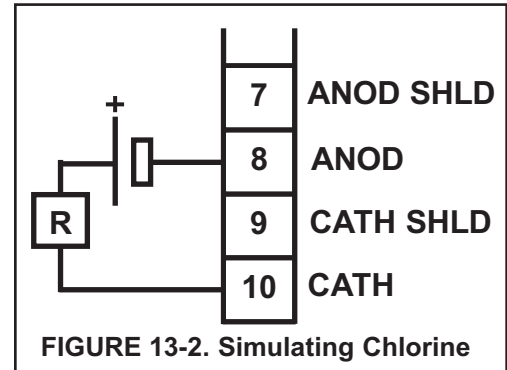
13.7 SIMULATING INPUTS — CHLORINE

To check the performance of the analyzer, use a decade box and 1.5V battery to simulate the current from the sensor. The battery, which opposes the polarizing voltage, is necessary to ensure that the sensor current has the correct sign.

1. Disconnect the anode and cathode leads from terminals 8 and 10 on TB1 and connect a decade box and 1.5V battery as shown in Figure 13-1. It is not necessary to disconnect the RTD leads.
2. Set the decade box to 1.4MΩ.
3. Note the sensor current. It should be about 960 nA. The actual value depends on the voltage of the battery. To view the sensor current, go to the main display and press INFO. Choose sensor 1 information. The input current is the second line in the display. Change the decade box resistance and verify that the correct current is shown. Calculate current from the equation:

$$\text{current (nA)} = \frac{V_{\text{battery}} - 250 \text{ (voltages in mV)}}{\text{resistance (M}\Omega\text{)}}$$

The voltage of a fresh 1.5 volt battery is about 1.6 volt (1600 mV).



13.8 SIMULATING INPUTS — TEMPERATURE

13.8.1 General.

The Model 56 accepts a Pt100 RTD. The Pt100 RTD is in a three-wire configuration. See Figure 13-3.

13.8.2 Simulating temperature

To simulate the temperature input, wire a decade box to the analyzer as shown in Figure 13-4.

To check the accuracy of the temperature measurement, set the resistor simulating the RTD to the values indicated in the table and note the temperature readings. The measured temperature might not agree with the value in the table. During sensor calibration an offset might have been applied to make the measured temperature agree with a standard thermometer. The offset is also applied to the simulated resistance. The analyzer is measuring temperature correctly if the difference between measured temperatures equals the difference between the values in the table to within $\pm 0.1^\circ\text{C}$.

For example, start with a simulated resistance of $103.9\ \Omega$, which corresponds to 10.0°C . Assume the offset from the sensor calibration was $-0.3\ \Omega$. Because of the offset, the analyzer calculates temperature using $103.6\ \Omega$. The result is 9.2°C . Now change the resistance to $107.8\ \Omega$, which corresponds to 20.0°C . The analyzer uses $107.5\ \Omega$ to calculate the temperature, so the display reads 19.2°C . Because the difference between the displayed temperatures (10.0°C) is the same as the difference between the simulated temperatures, the analyzer is working correctly.

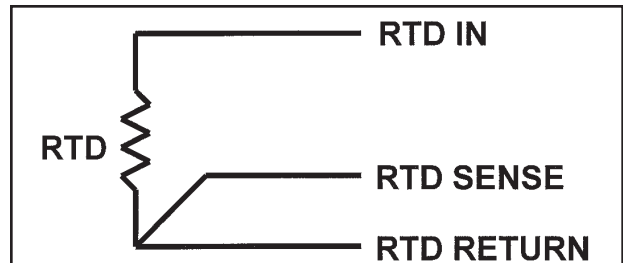


FIGURE 13-3. Three-Wire RTD Configuration.

Although only two wires are required to connect the RTD to the analyzer, using a third (and sometimes fourth) wire allows the analyzer to correct for the resistance of the lead wires and for changes in the lead wire resistance caused by temperature changes.

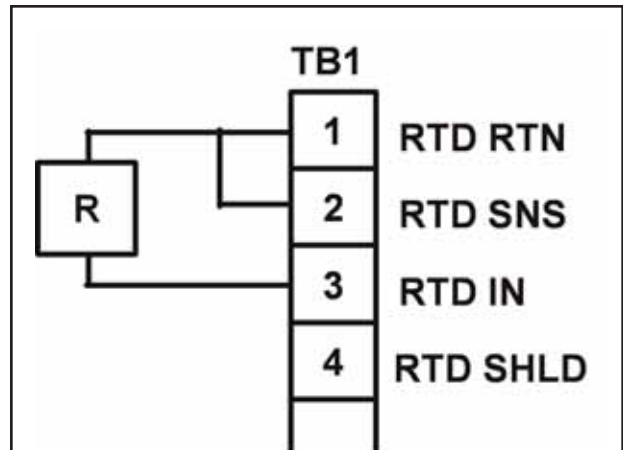


FIGURE 13-4. Simulating RTD Inputs.

Temp. ($^\circ\text{C}$)	Pt 100 (Ω)
0	100.0
10	103.9
20	107.8
25	109.7
30	111.7
40	115.5
50	119.4
60	123.2
70	127.1
80	130.9
85	132.8
90	134.7
100	138.5

SECTION 14. RETURN OF MATERIAL

14.1 GENERAL.

To expedite the repair and return of instruments, proper communication between the customer and the factory is important. Before returning a product for repair, call 1-949-757-8500 for a Return Materials Authorization (RMA) number.

14.2 WARRANTY REPAIR.

The following is the procedure for returning instruments still under warranty:

1. Call Rosemount Analytical for authorization.
2. To verify warranty, supply the factory sales order number or the original purchase order number. In the case of individual parts or sub-assemblies, the serial number on the unit must be supplied.
3. Carefully package the materials and enclose your "Letter of Transmittal" (see Warranty). If possible, pack the materials in the same manner as they were received.
4. Send the package prepaid to:

Emerson Process Management, Liquid Division
Liquid Division
2400 Barranca Parkway
Irvine, CA 92606

Attn: Factory Repair

RMA No. _____

Mark the package: Returned for Repair

Model No. _____

14.3 NON-WARRANTY REPAIR.

The following is the procedure for returning for repair instruments that are no longer under warranty:

1. Call Rosemount Analytical for authorization.
2. Supply the purchase order number, and make sure to provide the name and telephone number of the individual to be contacted should additional information be needed.
3. Do Steps 3 and 4 of Section 11.2.

NOTE

Consult the factory for additional information regarding service or repair.

WARRANTY

Seller warrants that the firmware will execute the programming instructions provided by Seller, and that the Goods manufactured or Services provided by Seller will be free from defects in materials or workmanship under normal use and care until the expiration of the applicable warranty period. Goods are warranted for twelve (12) months from the date of initial installation or eighteen (18) months from the date of shipment by Seller, whichever period expires first. **Consumables, such as glass electrodes, membranes, liquid junctions, electrolyte, o-rings, catalytic beads, etc., and Services are warranted for a period of 90 days from the date of shipment or provision.**

Products purchased by Seller from a third party for resale to Buyer ("Resale Products") shall carry only the warranty extended by the original manufacturer. Buyer agrees that Seller has no liability for Resale Products beyond making a reasonable commercial effort to arrange for procurement and shipping of the Resale Products.

If Buyer discovers any warranty defects and notifies Seller thereof in writing during the applicable warranty period, Seller shall, at its option, promptly correct any errors that are found by Seller in the firmware or Services, or repair or replace F.O.B. point of manufacture that portion of the Goods or firmware found by Seller to be defective, or refund the purchase price of the defective portion of the Goods/Services.

All replacements or repairs necessitated by inadequate maintenance, normal wear and usage, unsuitable power sources, unsuitable environmental conditions, accident, misuse, improper installation, modification, repair, storage or handling, or any other cause not the fault of Seller are not covered by this limited warranty, and shall be at Buyer's expense. Seller shall not be obligated to pay any costs or charges incurred by Buyer or any other party except as may be agreed upon in writing in advance by an authorized Seller representative. All costs of dismantling, reinstallation and freight and the time and expenses of Seller's personnel for site travel and diagnosis under this warranty clause shall be borne by Buyer unless accepted in writing by Seller.

Goods repaired and parts replaced during the warranty period shall be in warranty for the remainder of the original warranty period or ninety (90) days, whichever is longer. This limited warranty is the only warranty made by Seller and can be amended only in a writing signed by an authorized representative of Seller. Except as otherwise expressly provided in the Agreement, THERE ARE NO REPRESENTATIONS OR WARRANTIES OF ANY KIND, EXPRESS OR IMPLIED, AS TO MERCHANTABILITY, FITNESS FOR PARTICULAR PURPOSE, OR ANY OTHER MATTER WITH RESPECT TO ANY OF THE GOODS OR SERVICES.

RETURN OF MATERIAL

Material returned for repair, whether in or out of warranty, should be shipped prepaid to:

**Emerson Process Management
Liquid Division
2400 Barranca Parkway
Irvine, CA 92606**

The shipping container should be marked:

Return for Repair

Model _____

The returned material should be accompanied by a letter of transmittal which should include the following information (make a copy of the "Return of Materials Request" found on the last page of the Manual and provide the following thereon):

1. Location type of service, and length of time of service of the device.
2. Description of the faulty operation of the device and the circumstances of the failure.
3. Name and telephone number of the person to contact if there are questions about the returned material.
4. Statement as to whether warranty or non-warranty service is requested.
5. Complete shipping instructions for return of the material.

Adherence to these procedures will expedite handling of the returned material and will prevent unnecessary additional charges for inspection and testing to determine the problem with the device.

If the material is returned for out-of-warranty repairs, a purchase order for repairs should be enclosed.



*The right people,
the right answers,
right now.*

**ROSEMOUNT ANALYTICAL
CUSTOMER SUPPORT CENTER
1-800-854-8257**



ON-LINE ORDERING NOW AVAILABLE ON OUR WEB SITE
<http://www.raihome.com>

Specifications subject to change without notice.



Credit Cards for U.S. Purchases Only.



Emerson Process Management

2400 Barranca Parkway
Irvine, CA 92606 USA
Tel: (949) 757-8500
Fax: (949) 474-7250

<http://www.raihome.com>

